

TECHNICAL MANUAL

TRANSPORTABILITY GUIDANCE

TRUCKS, TACTICAL, 10-TON, 8X8, M.A.N.

**TRUCK TRACTOR W/CRANE, 10-TON, 8X8 M1001
(NSN 2320-12-191-5422)**

**TRUCK WRECKER W/CRANE, 10-TON, 8X8, M1002
(NSN 2320-12-191-5423)**

**TRUCK TRACTOR W/CRANE, 10-TON, 8X8, M1013
(NSN 2320-12-191-5424)**

**TRUCK TRACTOR W/O CRANE, 10-TON, 8X8, M1014
(NSN 2320-12-191-5425)**

Approved for public release; distribution is unlimited.

**TRANSPORTABILITY GUIDANCE
TRUCKS, TACTICAL, 10-TON, 8X8, M.A.N.
TRUCK TRACTOR W/CRANE, 10-TON, 8X8 M1001
(NSN 2320-12-191-5422)
TRUCK WRECKER W/CRANE, 10-TON, 8X8, M1002
(NSN 2320-12-191-423)
TRUCK TRACTOR W/CRANE, 10-TON, 8X8, M1013
(NSN 2320-12-191-424)
TRUCK TRACTOR W/O CRANE, 10-TON, 8X8, M1014
(NSN 2320-12-191-5425)**

		<i>Paragraph</i>	<i>Page</i>
Chapter 1.	INTRODUCTION		
	Purpose and Scope	1-1	1-1
	Safety	1-2	1-1
	Definitions of Warnings, Cautions, and Notes	1-3	1-1
	Reporting of Recommendations and Comments	1-4	1-1
Chapter 2.	TRANSPORTABILITY DATA		
Section I.	GENERAL		
	Scope	21	2-1
	Description	2-2	2-1
	Transportability Drawings	23	2-1
II.	CHARACTERISTICS AND REILATED DATA		
	General Characteristics	2-4	2-1
	Unusual Characteristics	2-5	2-11
	Hazardous and Dangerous Characteristics	2-6	2-11
Chapter 3.	SAFETY		
	General	31	31
	Specific Safety Requirements	32	3-1
Chapter 4.	AIR TRANSPORTABILITY GUII)ANCE		
	Scope	4-1	4-1
	Maximum Utilization of Aircraft	4-2	4-1
	Safety	4-3	4-1
	Responsibility	4-4	4-1
	Transport of M.A.N.Trucks by US Air Force Aircraft	4-5	4-1
	Internal and External Transport by US Army Aircraft	4-6	4-2
Chapter 5.	HIGHWAY TRANSPORTABILITY GUIDANCE		
Section I.	GENERAL		
	Scope	5-1	5-1
	Safety	5-2	5-1
II.	SELF-PROPELLED MOVEMENT		
	U.S.Highways	5-3	5-1
	European Highways	5-4	5-1
	Other Country Highways	5-5	5-1
	MTMC Assistance	5-6	5-1
III.	TRANSPORT BY SEMITRAILER		
	Transport of M.A.N.Trucks by Semitrailer	5-7	5-1
	Preparation for Transport	5-8	5-1
	Tiedown of M.A.N.Trucks	5-9	5-2

Approved for public release; distribution is unlimited.

*This manual supersedes TM 55-2320282-14, dated 9 Sep 85.

		<i>Paragraph</i>	<i>Page</i>
Chapter 6.	MARINE AND TERMINAL TRANSPORTABILITY GUIDANCE		
Section I.	GENERAL		
	Scope	6-1	6-1
	Safety	6-2	6-1
	Water Shipment	6-4	6-1
II.	LOADING AND SECURING		
	General Rules for Stowing	6-4	6-1
	General Cargo Ships, Container Ships, and Roll-on/Roll-off (RORO) Ships.....	6-5	6-3
	Barges and Lighters	6-6	6-4
	Landing Ships, Landing Craft, and Amphibious Vehicles	6-7	6-4
Chapter 7.	RAIL TRANSPORTABILITY GUIDANCE		
Section I.	GENERAL		
	Scope	7-1	7-1
	Maximum Utilization of Railcars	7-2	7-1
	Safety	7-3	7-1
II.	TRANSPORT ON CONUS RAILWAYS		
	General	7-4	7-1
	Preparation for Loading	7-5	7-1
	Loading on General-Purpose Flatcars	7-6	7-1
III.	TRANSPORT ON FOREIGN RAILWAYS		
	General	7-7	7-1
	Transport on Foreign-Service Flatcars	7-8	7-1
Appendix	REFERENCES		A-1

LIST OF ILLUSTRATIONS

Figure	Title	<i>Page</i>
2-1	M1001 8x8 10-ton truck tractor	2-2
2-2	M1002 8x8 10-ton truck wrecker	2-3
2-3	M1013 8x8 10-ton truck tractor	2-4
2-4	M1014 8x8 10-ton truck tractor	2-5
2-5	Left-side view of M1001 truck tractor	2-6
2-6	Left-side view of M1002 truck wrecker	2-7
2-7	Left-side view of M1013 truck tractor	2-8
2-4	Left-side view of M1014 truck tractor	2-9
2-9	Rear view of a typical M.A.N. truck	2-10
4-1	Typical tiedown diagram of the M.A.N. truck in USAF C-130 aircraft	4-3
4-2	Typical tiedown diagram of the M.A.N. truck in USAF C-141 aircraft	4-5
4-3	Typical tiedown diagram of the M.A.N. truck in USAF C-5 aircraft	4-7
5-1	Tiedown of the M.A.N. truck on a semitrailer	5-3
5-2	Tiedown of the M.A.N. truck on a semitrailer (rear view)	5-4
6-1	Lifting diagram for the M.A.N. truck	6-2
6-2	Blocking of the M.A.N. truck in a general cargo vessel	6-3
7-1	Blocking and tiedown of the M.A.N. truck on a general-purpose flatcar	7-2
7-2	Blocking and tiedown details	7-3

LIST OF TABLES

Table	Title	<i>Page</i>
4-1	Tiedown Data for the M.A.N. Truck in USAF C-130 Aircraft (Fig 4-1)	4-4
4-2	Tiedown Data for the M.A.N. Truck in USAF C-141 Aircraft (Fig 4-2)	4-6
4-3	Tiedown Data for the M.A.N. Truck in USAF C-5 Aircraft (Fig 4-3)	4-8
5-1	Bill of Materials for Tiedown of the M.A.N. Truck on M871 and M872 Semitrailers (Figs 5-1 and 5-2)	5-5
5-2	Application of Materials for Tiedown of the M.A.N. Truck on M871 and M872 Semitrailers (Figs 5-1 and 5-2)	5-5
6-1	Bill of Materials for Blocking of the M.A.N. Truck in a General Cargo Vessel (Fig 6-2)	6-3
6-2	Application of Materials for Blocking of the M.A.N. Truck in a General Cargo Vessel (Fig 6-2)	6-3
7-1	Bill of Materials for Blocking and Tiedown of the M.A.N. Truck on CONUS General-Purpose Flatcar (Fig 7-1)	7-4
7-2	Application of Materials for Blocking and Tiedown of the M.A.N. Truck on CONUS General-Purpose Flatcar (Fig 7-1)	7-4

CHAPTER 1 INTRODUCTION

1-1. Purpose and Scope

- a. This manual provides transportability guidance for logistical handling and movement of the Maschienfabrik Augsburg-Nurnberg (M. A. N.) trucks: M1001, M1002, M1013, and M1L014 models. It contains information considered appropriate for safe transport of the trucks. It also includes technical data, as well as safety considerations, which will be useful in planning for worldwide movement by the various transportation modes. Where appropriate, metric equivalents appear in parentheses after the dimensions or other measurements.
- b. This manual is for transportation officers and other personnel responsible for providing movement or for providing transportation services.

1-2. Safety

Appropriate precautionary measures required during movement of the trucks are in chapter 3.

1-3. Definitions of Warnings, Cautions, and Notes

Throughout this manual, warnings, cautions, and notes emphasize important or critical guidance. They are used for the following conditions:

- a. *Warning.* Instructions that, if not followed, could result in injury to or death of personnel
- b. *caution.* Instructions that, if not strictly observed, could result in damage to or destruction of equipment.
- c. *Note.* A brief statement for use as necessary to emphasize a particular operating procedure or condition.

1 4. Reporting of Recommendations and Comments

Individual users of this manual are encouraged to submit comments and recommended changes for its improvement. Comments and recommendations should be prepared on DA Form 2028 (Recommended Changes to Publications and Blank Forms) and forwarded to Commander, Military Traffic Management Command Transportation Engineering Agency, ATTN: MTTE-TRV, PO Box 6276, Newport News, VA 23606-0276. Electrically transmitted messages should be addressed to CDR MTMCTEA FT EUSTIS VA //MTTE-TRV//. A reply will be furnished by this command.

CHAPTER 2

TRANSPORTABILITY DATA

Section I. GENERAL

2-1. Scope

This chapter provides a general description and identification drawings of the M.A.N. trucks, as well as tabulated transportability data, that will assist in transporting these vehicles.

2-2. Description

The M.A.N. tactical vehicle is an 8x8 truck with a diesel engine and a 10-ton capacity. It is dedicated to the PERSHING II (PII) and the ground launch cruise missile (GLCM3 systems. The M1001, M1013, and M1014 are truck tractors. The M1002 model is a wrecker dedicated to recovery operations for the PII and GLCM systems.

a. *M1001 8x8 10-Ton Truck Tractor (fig 2-1).* The M1001 truck tractor has an 8-ton material handling crane, a 30-kilowatt (kW) generator, and a self-recovery winch. This model, the dedicated prime mover for the PII semitrailer, has a fifth wheel for a 2-inch kingpin.

b. *M1002 8x8 10-Ton Truck Wrecker (fig 2-2).* The M1002 wrecker has a Rotzler recovery unit, earth spades, 8-ton material handling crane, and carriers for a truck spare tire: and two PII semitrailer spare tires.

c. *M1013 8x8 10-Ton Truck Tractor (fig 2-3).* The M1013 truck tractor has a 2-ton material handling crane and a self-recovery winch. This model, a dedicated prime mover for the GLCM semitrailer, has a fifth wheel for a 3/4-inch Kingpin.

d. *M1014 8x8 10-Ton Truck Tractor (fig 2-4).* The M1014 truck tractor has a fifth wheel for a 3/4-inch kingpin and extra tire carrier for the semitrailer spare tire. This model is also a dedicated prime mover for the GLCM semitrailer.

2-3. Transportability Drawings

Figures 2-5 through -9 are detailed transportability drawings of the M.A.N. trucks, with dimensions and tiedown provision load-rating capacities.

Section II. CHARACTERISTICS AND RELATED DATA

2-4. General Characteristics

The characteristics and data below apply to the vehicle model number shown. Any changes in the vehicle characteristics may affect the loadability of the trucks as related to the guidance in this manual.

a. <i>M1001 8x8 10-Ton Truck Tractor with Crane.</i>	
National stock number	2320-12-191-5422
Line item number	T88745
Dimensions and shipping data:	
Length, operational	337.3 in. (8.57 m)
Width, operational	119.0 in. (3.02 m)
Reduced	98.4 in. (2.50 m)
Height, operational	121.7 in. (3.09 m)
Reduced, without spare tire and generator	108.3 in. (2.75 m)
Reduced, without spare tire and generator and with suspension system lowered	104.5 in. (2.65 m)
Cube, operational	2.827 ft3 (80.00 m3)
Reduced, without spare tire and generator	2,080 ft3 (58.88 m3)
Reduced, without spare tire and generator and with suspension system	

lowered	2,007 ft3 (56.80 me)
Weight:	
Curb	36,803 lb (16 694 kg)
Gross	45,160 lb (20 484 kg)
Axle weight (curb):	
No. 1 axle	12,800 lb (5806 kg)
No. 2 axle	10,903 lb (4946 kg)
No. 3 axle	6,943 lb (3149 kg)
No. 4 axle	6,157 lb (2793 kg)
Axle weight (gross)	
No. 1 axle	16,246 lb (7369 kg)
No. 2 axle	12,764 lb (5790 kg)
No. 3 axle	9,366 lb (4248 kg)
No. 4 axle	6,784 lb (3077 kg)
Center of gravity:	
Longitudinal, in front of fourth axle:	143.0 in. (3.63 m)
Vertical, below top of longitudinal frame	2.4 in. (0.60 m)
Military load classification (MLC)	18
b. <i>M1002 8x8 10-Ton Truck Wrecker.</i>	
National stock number	2320-12-191-5423
Line item number	T94641
Dimensions and shipping data:	
Length, operational	367.5 in. (9.33 m)
Width, operational	119.0 in. (3.02 m)

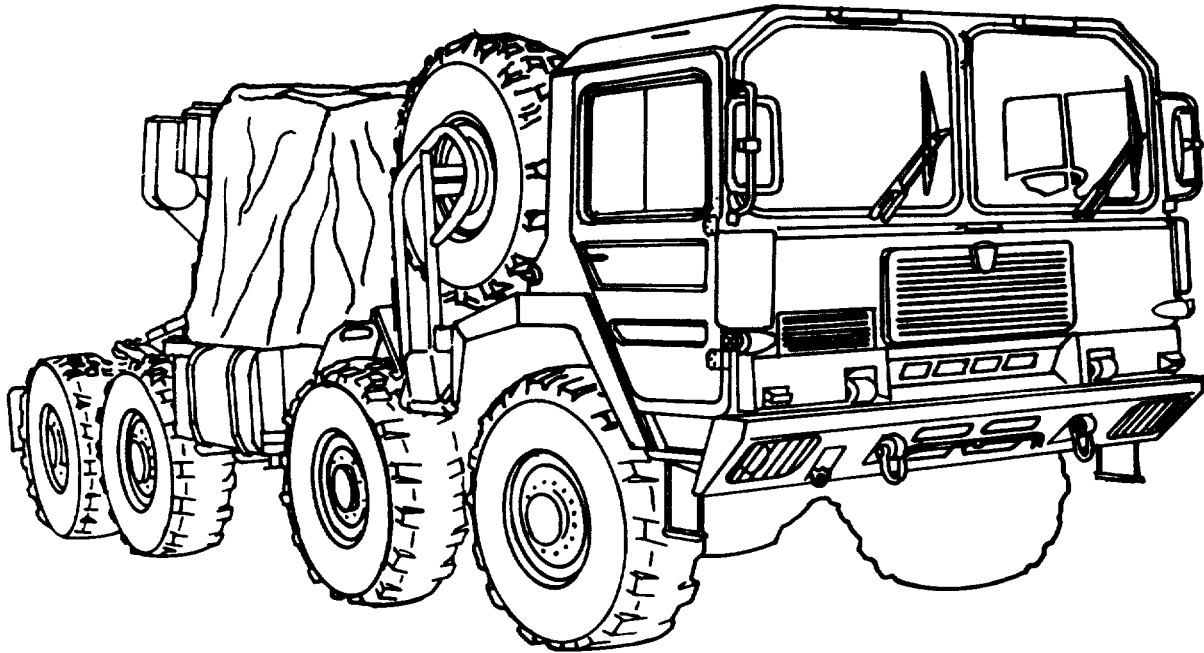

RIGHT FRONT VIEW

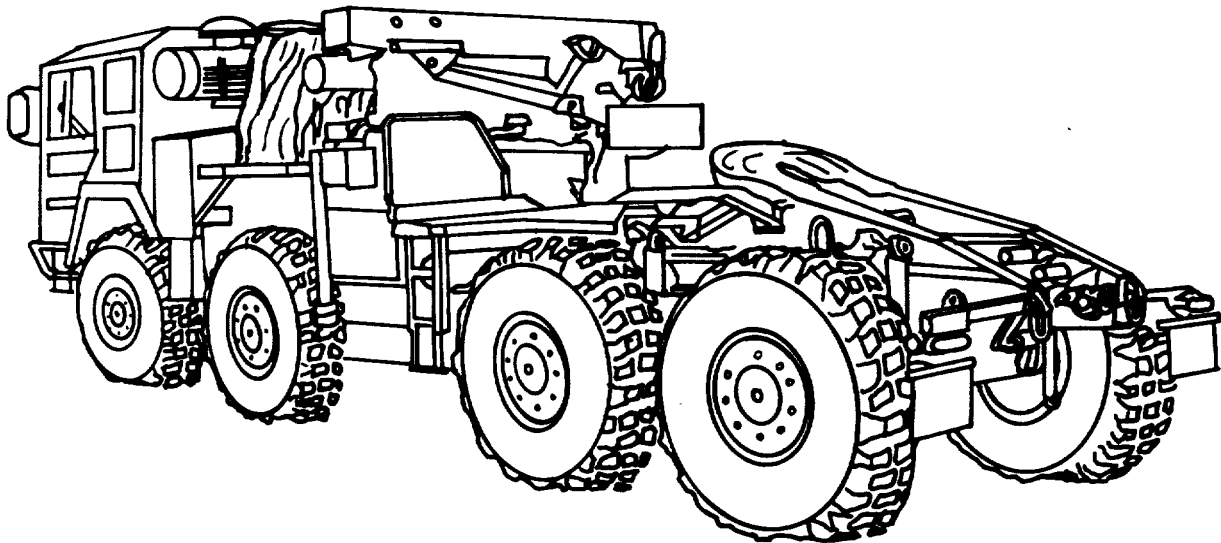

LEFT REAR VIEW

Figure 2-1. M1001 8x8 10-ton truck tractor.

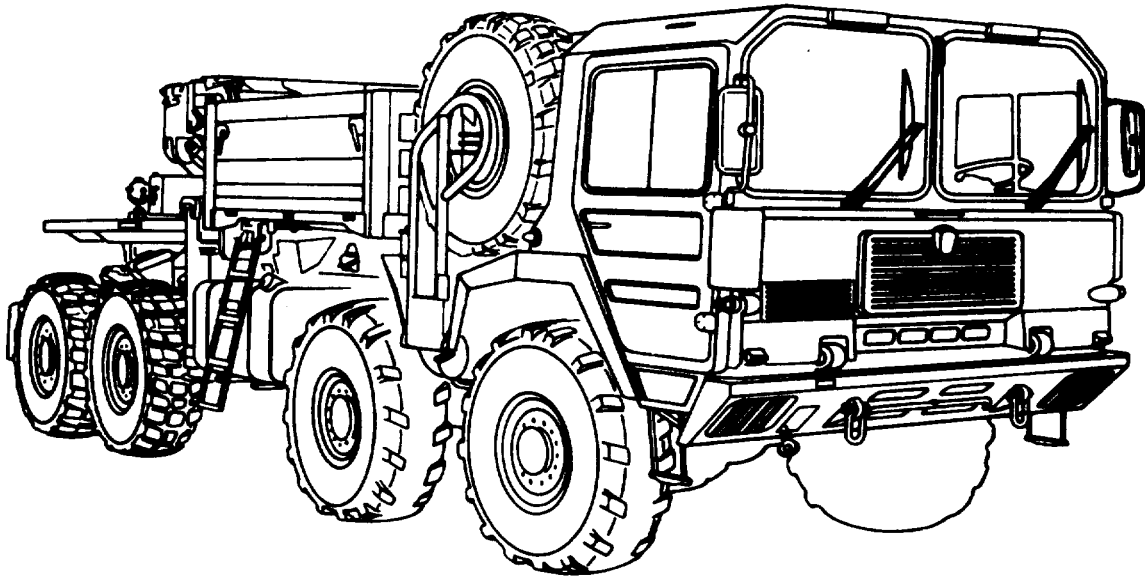

RIGHT FRONT VIEW

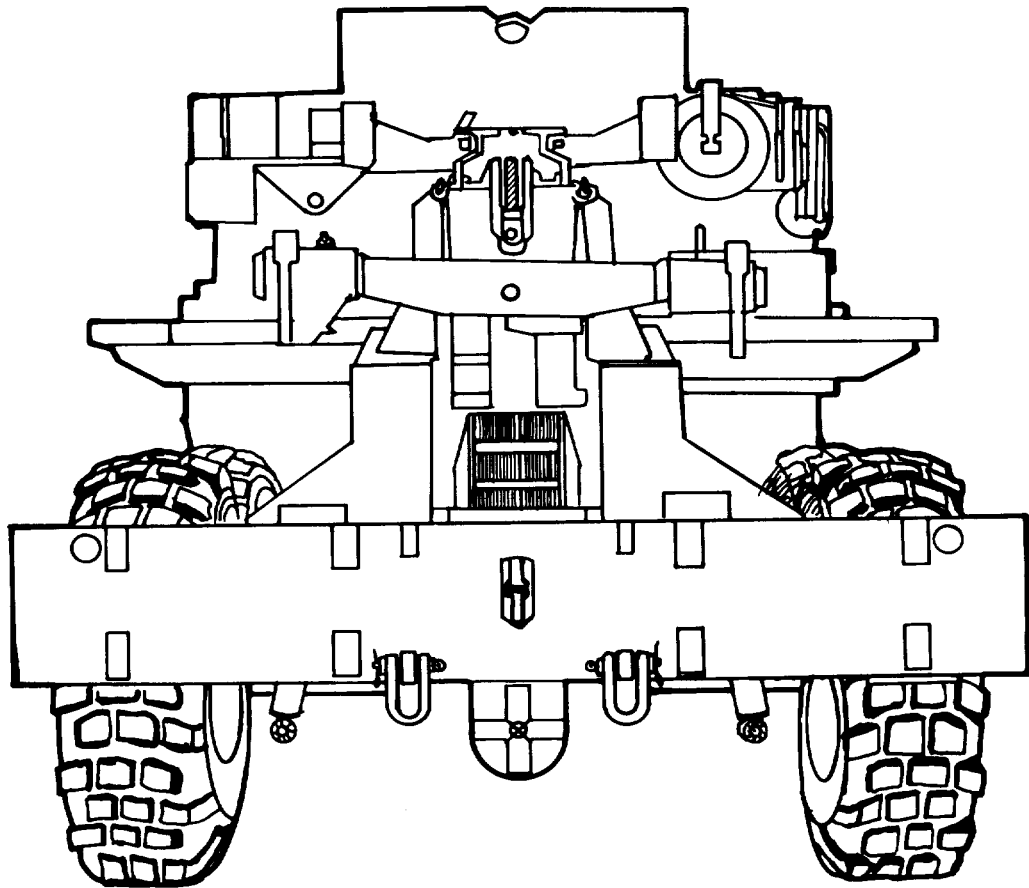

REAR VIEW

Figure 2-2. M1002 8x8 10-ton truck wrecker.

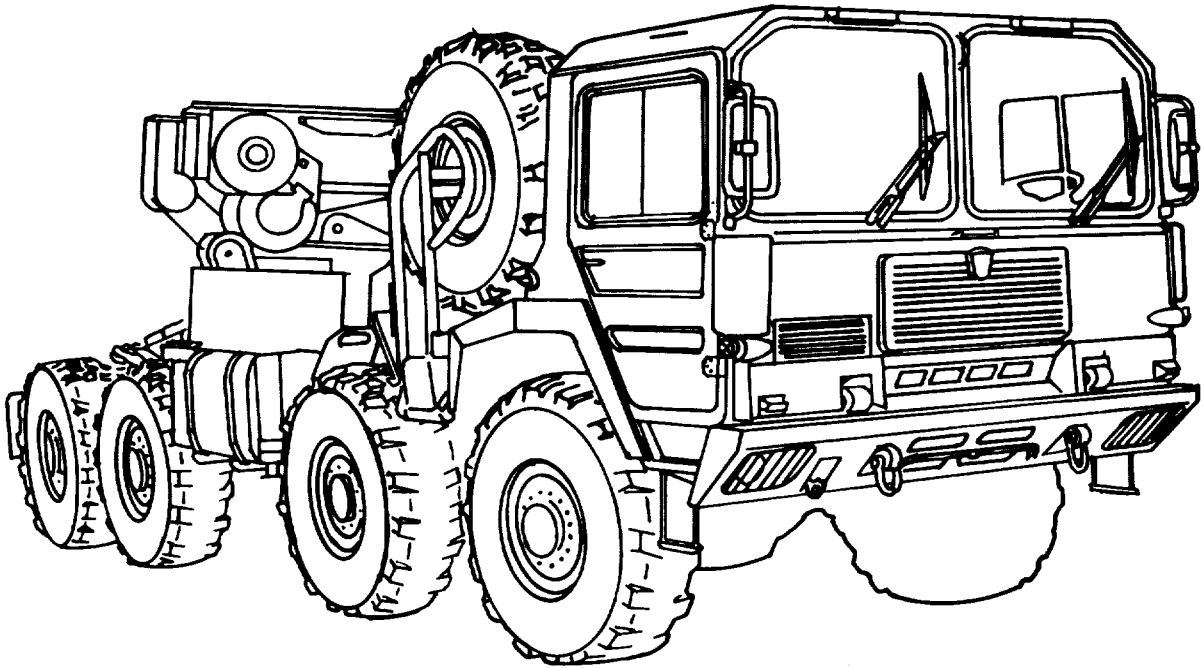

RIGHT FRONT VIEW

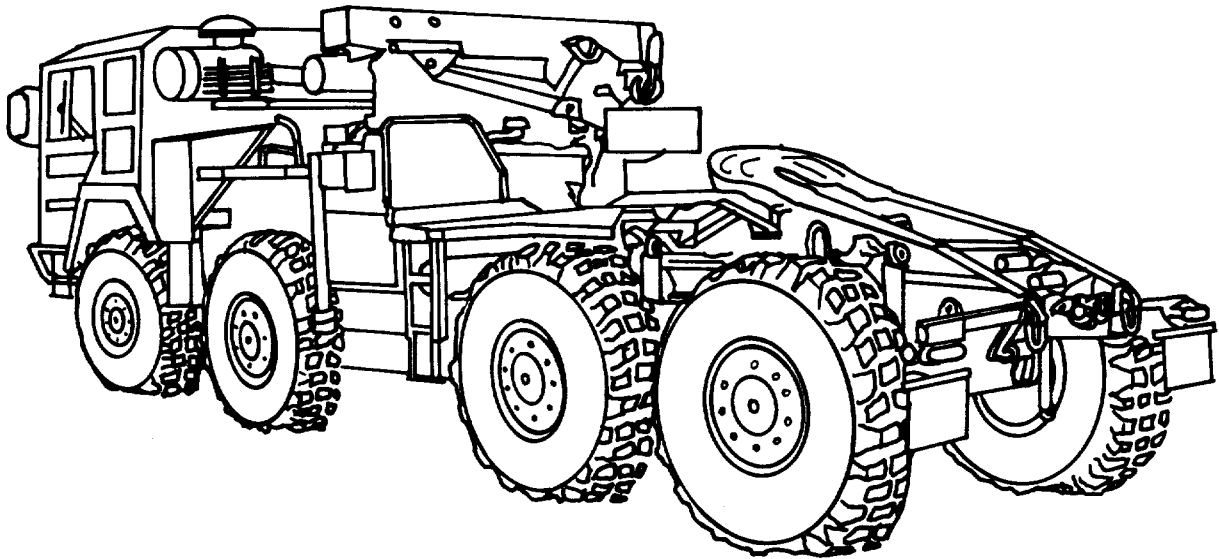

LEFT REAR VIEW

Figure 2-3. M1013 8x8 10-toil truck tractor.

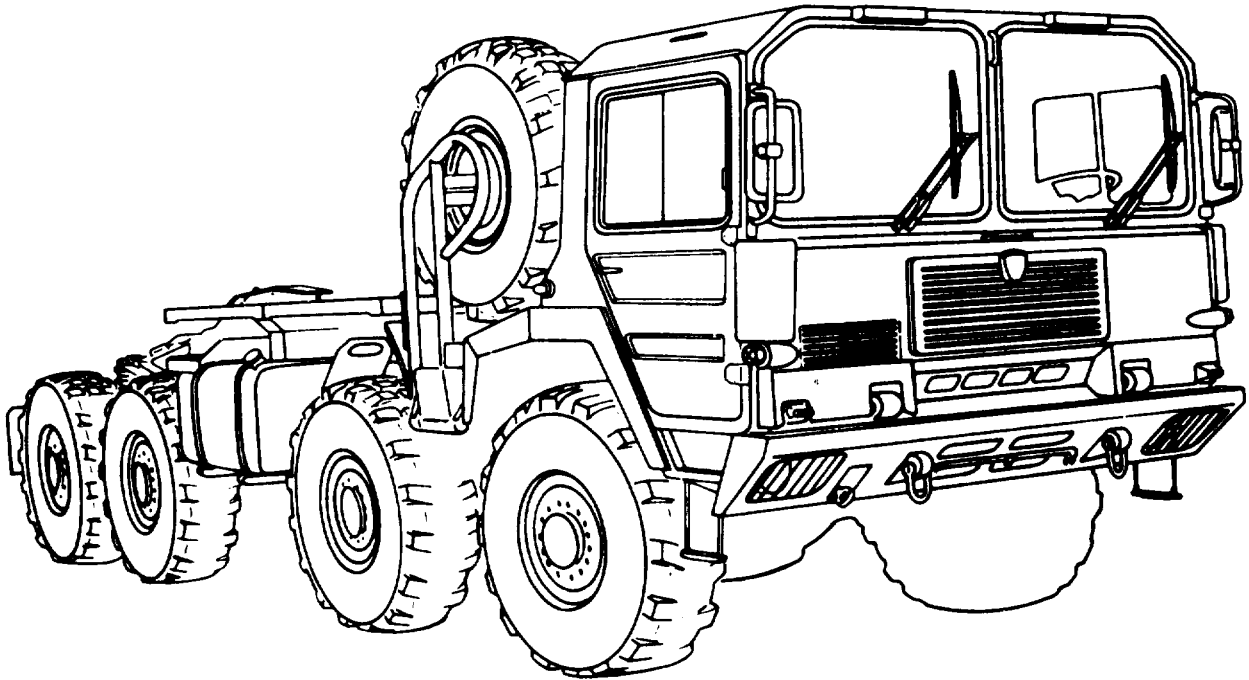

RIGHT FRONT VIEW

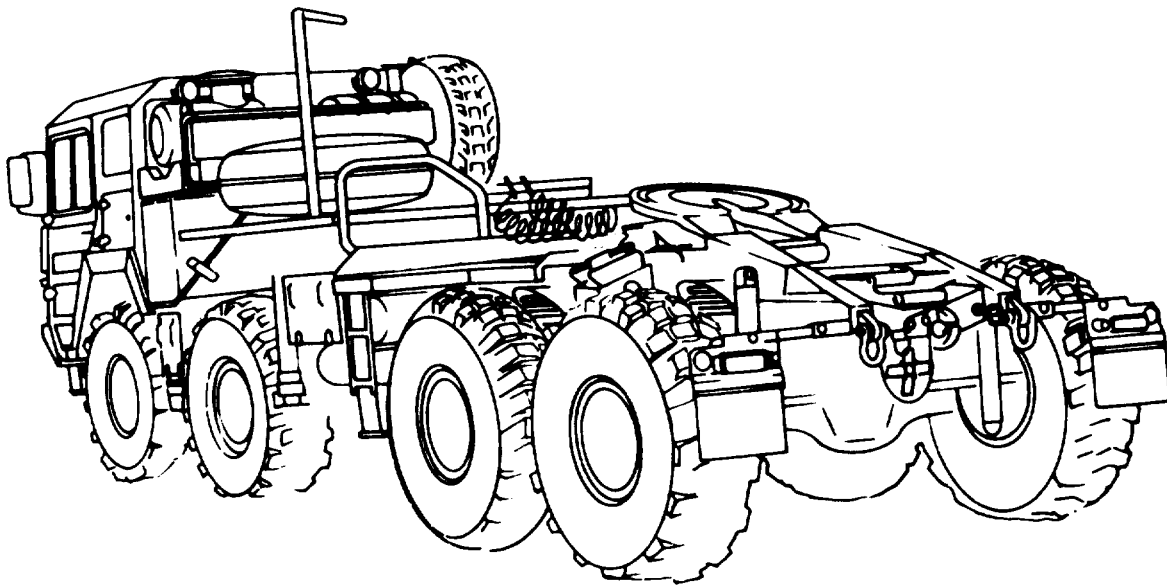

LEFT REAR VIEW

Figure 2-4. M1014 8x8 10-ton truck tractor

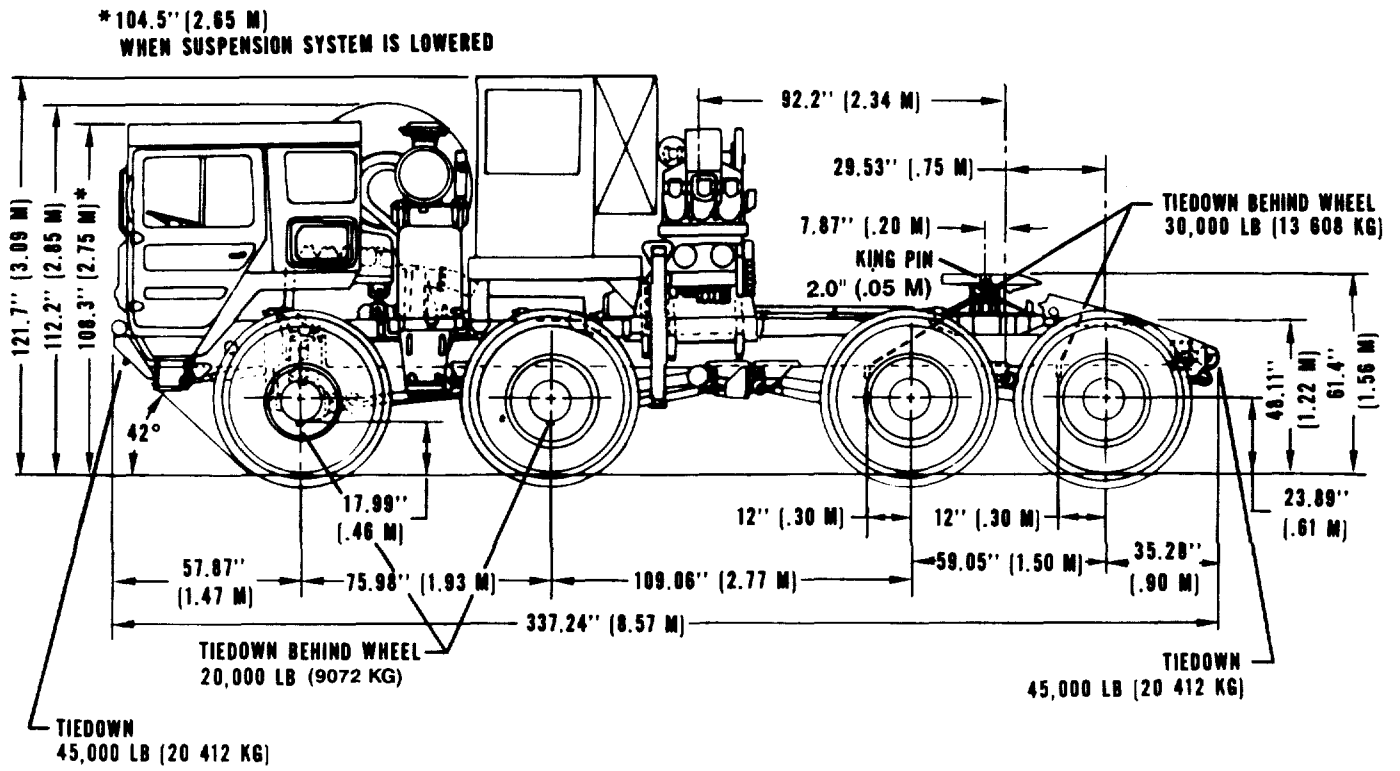

Figure 2-5. Left-side view of M1001 truck tractor.

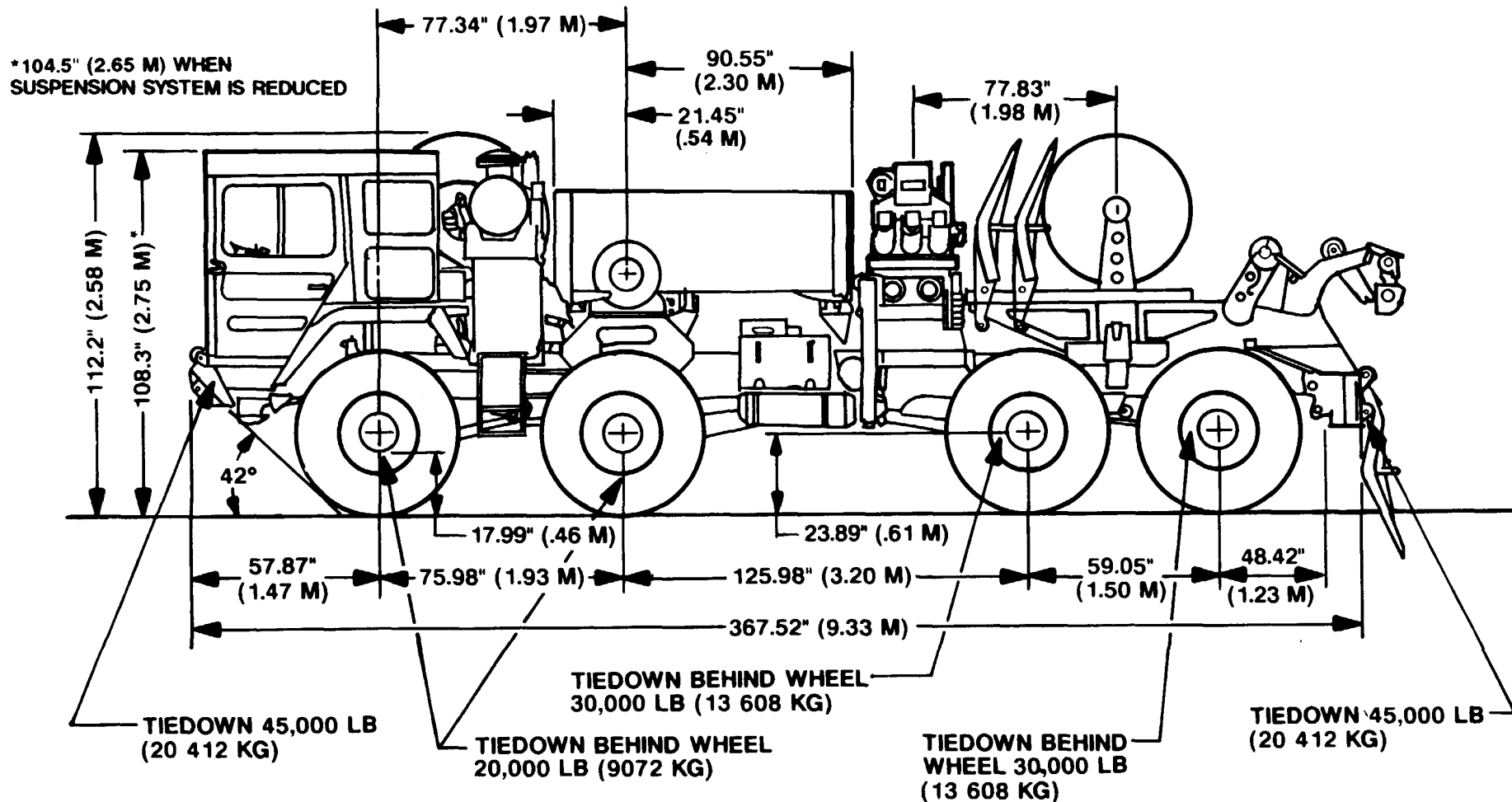

Figure 2-6. Left-side view of M1002 truck wrecker.

*104.5" (2.65 M)
 WHEN SUSPENSION SYSTEM IS LOWERED

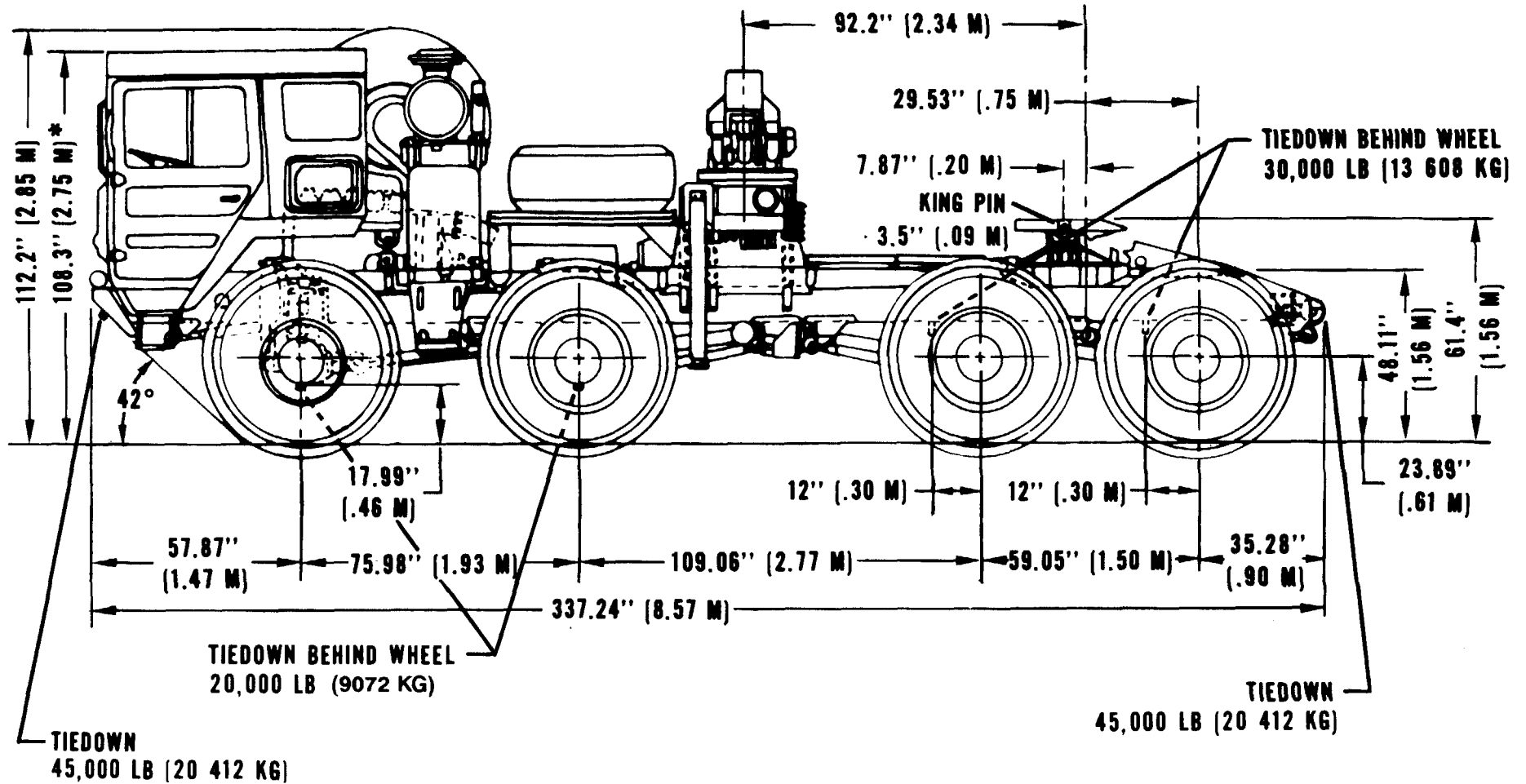

Figure 2-7. Left-side view of M1013 truck tractor.

*104.5" (2.65 M)
WHEN SUSPENSION SYSTEM IS LOWERED

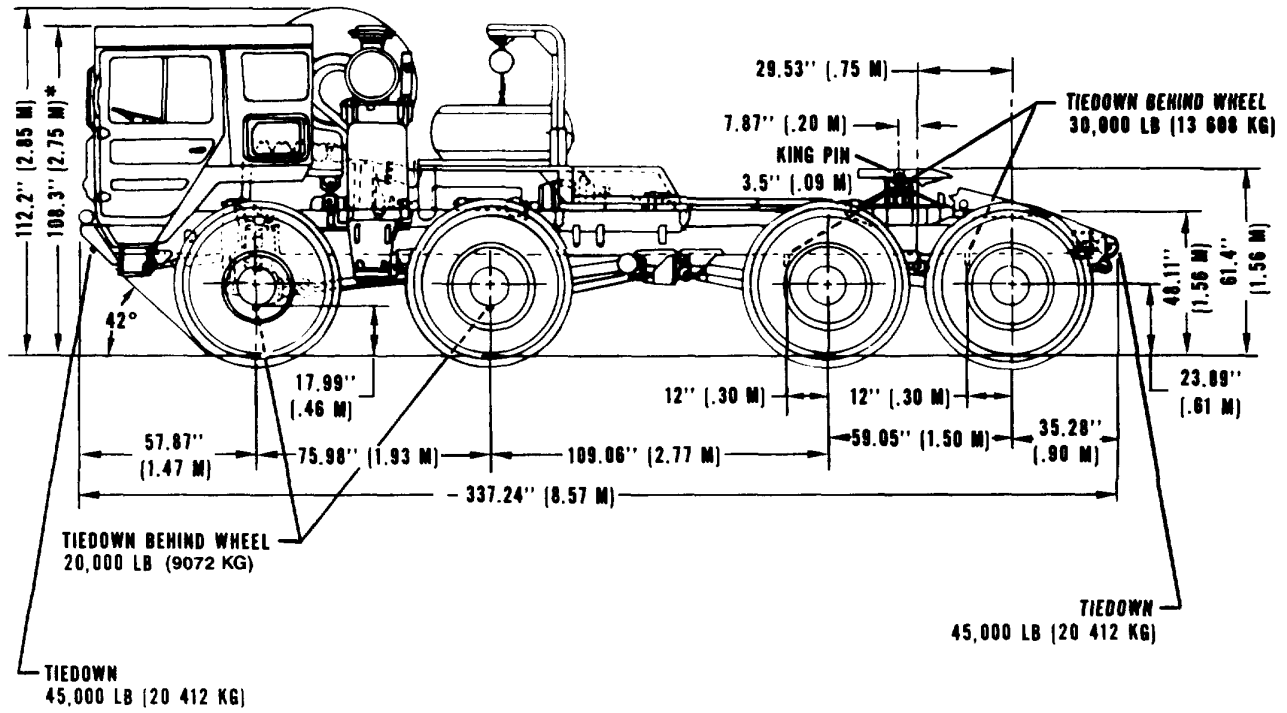
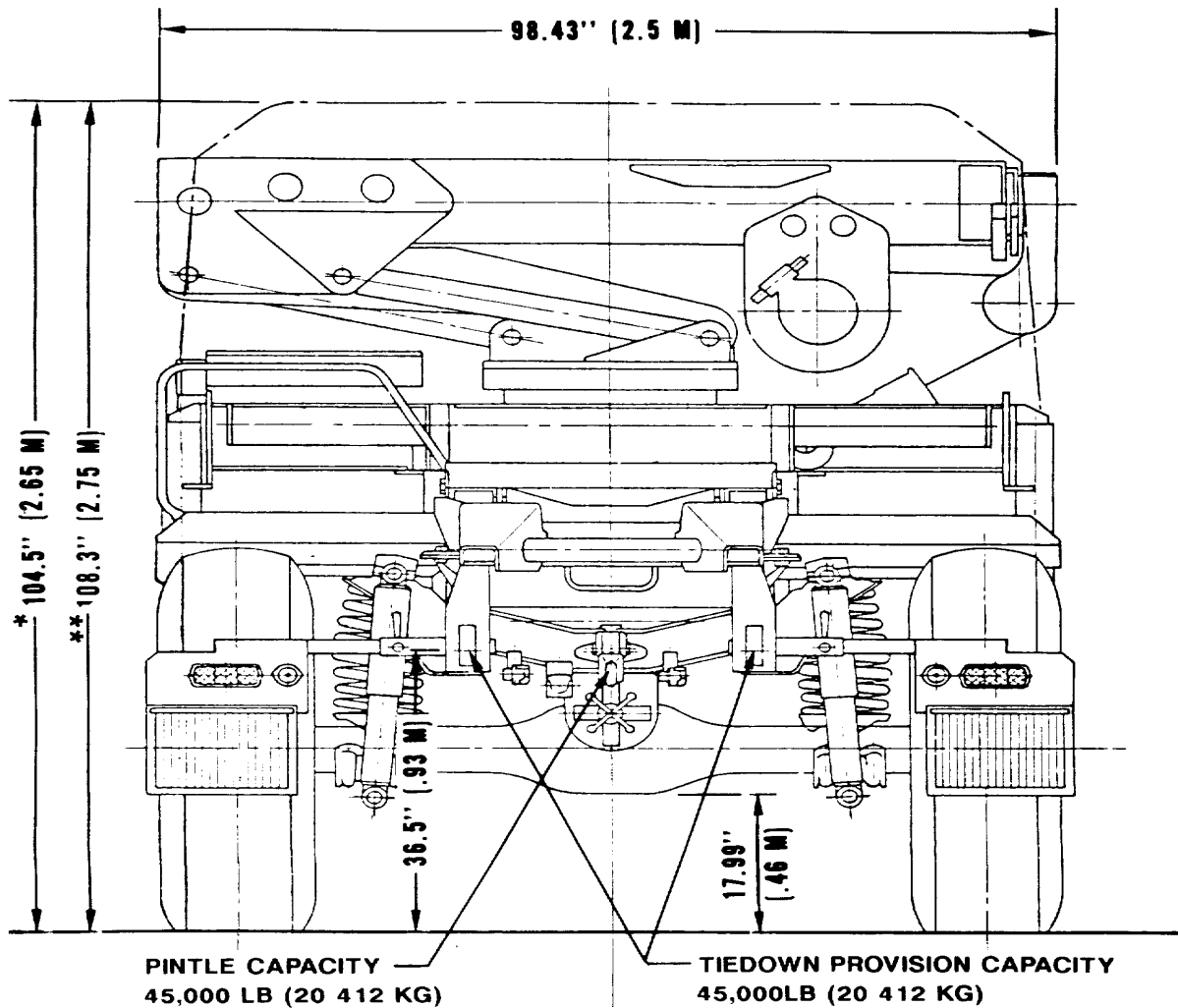

Figure 28. Left-side view of M1014 truck tractor.



* WHEN SUSPENSION SYSTEM IS LOWERED
 ** HEIGHT IS 112.2" (2.85 M) WITH SPARE TIRE

Figure 2-9. Rear View of a typical M. A. N. Truck

Reduced.....98.4 in.(2.50 m)
 Height, operational 112.2 in.(2.85 m)
 Reduced, without spare
 tire 108.3 in.(2.75 m)
 Reduced, without spare tire and
 with suspension system
 lowered 104.5 in.(2.65 m)
 Cube, operational2,840 ft3 (80.36 m3)
 Reduced, without spare
 tire2,266 ft3 (64.15 m3)

Reduced, without spare tire and
 with suspension system
 lowered 2,187 ft3 (61.89 m3)
 Weight:
 Curb 41,009 lb (18 642 kg)
 Gross 48,785 lb (22 128 kg)
 Axle weight (curb):
 No. 1 axle 12,416 lb (5632 kg)
 No. 2 axle 12,419 lb (5633 kg)
 No. 3 axle 8,458 lb (3836 kg)

No. 4 axle 7,806 lb (3541 kg)
 Axle weight (gross)
 No. 1 axle 13,873 lb (6292 kg)
 No. 2 axle 12,304 lb (5581 kg)
 No. 3 axle 11,757 lb (5333 kg)
 No. 4 axle 10,851 lb (4922 kg)
 Center of gravity:
 Longitudinal, in front of fourth
 axle 146.5 in.(3.72 m)
 Vertical, below top of longitudinal
 frame 2.8 in. (.070 m)
 Military load classification (MLC) 21
c. M1013 8x8 10-Ton Truck Tractor with Crane.
 National stock number 2320-12-191-5424
 Dimensions and shipping data:
 Length, operational 337.3 in.(8.57 m)
 Width, operational 119.0 in.(3.02 m)
 Reduced 98.4 in.(2.50 m)
 Height, operational 112.2 in.(2.85 m)
 Reduced, without spare tire 108.3 in.(2.75 m)
 Reduced, without spare tire and
 with suspension system
 lowered 104.5 in.(2.65 m)
 Cube, operational 2,606 ft³ (73.75 m³)
 Reduced, without spare
 tire 2,080 ft³ (58.88 m³)
 Reduced, without spare tire and
 with suspension system
 lowered 2,007 ft³ (56.79 m³)
 Weight:
 Curb 35,966 lb (16 314 kg)
 Gross 36,320 lb (16 475 kg)
 Axle weight (curb):
 No. 1 axle 12,508 lb (5674 kg)
 No. 2 axle 10,291 lb (4668 kg)
 No. 3 axle 7,095 lb (3218 kg)
 No. 4 axle 6,072 lb (2754 kg)
 Axle weight (gross)
 No. 1 axle 12,810 lb (5811 kg)
 No. 2 axle 10,153 lb (4605 kg)
 No. 3 axle 7,178 lb (3256 kg)
 No. 4 axle 6,179 lb (2803 kg)
 Center of gravity:
 Longitudinal, in front of fourth
 axle 134.4 in.(3.44 m)
 Vertical, below top of longitudinal
 frame 0.4 in.(0.10 m)
 Military load classification (MLC) 17
d. M1014 8x8 10-Ton Truck Tractor
 National stock number 2320-12-191-5425
 Dimensions and shipping data:
 Length, operational (not
 reducible) 337.3 in.(8.57 m)
 Width, operational 119.0 in.(3.02 m)
 Reduced 98.4 in. (2.50 m)
 Height, operational 112.2 in.(2.85 m)
 Reduced, without
 spare tire 108.3 in.(2.75 m)

Reduced, without spare tire and
 with suspension system
 lowered 104.5 in.(2.65 m)
 Cube, operational 2,606 ft³ (73.75 m³)
 Reduced, without spare
 tire 2,080 ft³ (58.88 m³)
 Reduced, without spare tire and
 with suspension system
 lowered 2,077 ft³ (56.79 m³)
 Weight:
 Curb 30,820 lb (13 980 kg)
 Gross 32,325 lb (14 662 kg)
 Axle weight (curb):
 No. 1 axle 11,042 lb (5009 kg)
 No. 2 axle 8,828 lb (4004 kg)
 No. 3 axle 5,940 lb (2694 kg)
 No. 4 axle 5,010 lb (2273 kg)
 Axle weight (gross)
 No. 1 axle 11,577 lb (5251 kg)
 No. 2 axle 9,362 lb (4247 kg)
 No. 3 axle 6,240 lb (2830 kg)
 No. 4 axle 5,146 lb (2334 kg)
 Center of gravity:
 Longitudinal, in front of fourth
 axle 143.9 in.(3.65 m)
 Vertical, below top of longitudinal
 frame 3.5 in.(0.90 m)
 Military load classification (MLC) 15
e. M.A.N. Vehicles. The following performance
 characteristics are for all M.A.N. vehicles.
 Maximum speed 55 mph (89 km/h)
 Cruising range 400 mi (644 km)
 Fuel tank capacity (diesel) 100 gal (379 L)
 Angle of approach 42°
 Ground clearance 17.99 in.(0.46 m)
 Tire size 16:00 x 20

2-5. Unusual Characteristics

The M.A.N. trucks have no unusual characteristics that would require special attention be given to temperature, atmospheric pressure, or humidity variations during exposure to normal transportation environments.

2-6. Hazardous and Dangerous Characteristics

The M.A.N. trucks will not present any special hazardous or dangerous characteristics during exposure to normal transportation environments.

NOTE

Those regulations and/or transportation procedures normally associated with vehicles containing diesel fuel will apply.

CHAPTER 3

SAFETY

3-1. General

General safety considerations and precautions for the handling and movement of M.A.N. trucks are as follows:

- a. The truck will not be left unattended while engine is running.
- b. All personnel must stay clear of the truck when it is being operated in reverse, and the area will be clear of obstacles.
- c. Personnel must not walk under the truck when the truck is being lifted.

WARNING

No personnel will be in the immediate area when the truck is lowered. Fire extinguishers must be readily available during all loading and unloading operations. Proper ventilation must be provided during loading and unloading operations if the

truck engine is running. Prolonged inhalation of carbon monoxide fumes could prove fatal.

CAUTION

The vehicle lowering system is to be used only for loading and transporting purposes. The vehicle must not exceed 5 mph when it is in the lowered position. The steering capability is reduced to slight left and right turns. Therefore, no attempt should be made to make sharp turns with the vehicle in lowered position because steering or suspension components may become damaged.

3-2. Specific Safety Requirements

Pertinent safety requirements by individual mode are in the appropriate chapters.

CHAPTER 4

AIR TRANSPORTABILITY GUIDANCE

4-1. Scope

This chapter provides air transportability guidance for movement of the M.A.N. trucks. It covers technical and physical characteristics, as well as safety considerations. It also prescribes the materials required to prepare, load, and tie down system equipment on, or offload from, US Air Force cargo aircraft.

4-2. Maximum Utilization of Aircraft

The loads described in this chapter are not maximum loads. General guidance on total cargo loads and operating ranges is in TM 38-236/AFP 71-8. Additional cargo and/or personnel within allowable load limits and restrictions, prescribed by pertinent safety regulation, can be transported.

4-3. Safety

Besides the safety precautions in chapter 3, the following procedures apply:

- a. The activity offering the equipment for air transport must notify the aircraft commander, or designated representative, when hazardous materials are being shipped. These materials must be prepared for shipment according to TM 3-250/AFR 71-4.
- b. The vehicle fuel tanks must not be more than one-half full.
- c. The vehicle must be tied down according to procedures in TO 1C-XXX-9.
- d. Each vehicle must be checked carefully to ensure that all loose items are properly secured.

WARNING

Fire extinguishers must be readily available during all loading and unloading operations. Proper ventilation must be provided during loading and unloading. Prolonged exposure to carbon monoxide fumes may be fatal.

CAUTION

The trucks must not exceed 3 mph inside the aircraft or on loading ramps.

4-4. Responsibility

The loadmaster will ensure that securing of the loaded equipment is according to restraint criteria outlined in TO 1C-XXX-9.

4-5. Transport of M.A.N. Trucks by US Air Force Aircraft

The M.A.N. trucks are transportable in C-130, C-141, and C-5 aircraft. The procedures in this manual and those in TO 1C-XXX-9 apply.

a. Preparation of Equipment

- (1) Remove and stow communication antennas, for all aircraft.
- (2) Stow and secure all basic issue items (BII) not required for transport, for all aircraft.
- (3) For C-130 and C-141 transport, remove the vehicle spare tires. Also, remove the semitrailer spare tires carried by the M1002.
- (4) For C-130 and C-141 transport, remove the 30 kW generator from the M1001 and transport it separately.
- (5) Lower the vehicle suspension and tie down the axles according to procedures in TM 9-2320-28210 (operator's manual for the M.A.N. trucks), for C-130 and C-140 transport.

WARNING

Consult TM 38-250/AFR 71-4 to ensure compatibility of any additional cargo considered for loading with the M.A.N. trucks.

b. Loading.

- (1) C-130 and C-141 Aircraft.
 - (a) The M.A.N. trucks are transportable in C-130 and C-141 aircraft only in their reduced configuration. In their operational configuration, their height exceeds the aircraft cargo compartment height. To reduce the vehicle height, remove the generator from the M1001 truck, remove the spare tires from all vehicles, and tie down the suspension system on all vehicles. The reduced height of 104.5 inches will allow all M.A.N. trucks to meet dimensional restrictions for C-130 and C-141 transport. The axle weights may not exceed 13,000 pounds and gross vehicle weight may not exceed 43,000 pounds. To comply with the weight restriction, remove the on vehicle equipment (OVE) from the M1001 and M1002 trucks. Also, remove and ship separately the earth spades, recovery unit, and subframe on the M1002.
 - (b) The articulation of the M.A.N. trucks suspension is not sufficient for loading by use of the C-130 ramp, because of the lowering and tiedown of the suspension system. Load the vehicles on the C-130 straight in, using a 40K loader or an M870 semitrailer as a loading ramp, with the aircraft ramp

in the coplanar position. The M1002 wrecker (41,099 pounds) cannot be loaded with the 40K loader. When using the M870 trailer, back all vehicles aboard the C-130. During loading of the C-141 aircraft, the M.A.N. trucks can be loaded from ground level without the aid of materials handling equipment. Place the aircraft ramp at ground position and back the vehicles aboard. Aircraft height limitations prevent drive-in loading from ground level.

(2) *C-5 Aircraft.* The M.A.N. truck can be transported in the operational configuration in C-

5 aircraft. No special procedures or materials handling equipment are required.

c. *Tiedown.* The trucks will be tied down according to section IV of the applicable TO 1C-XXX-9. Figures 4-1 through 4-3 show suggested tiedown patterns. Tables 4-1 through 4-3 list the tiedown devices required, location of points, and fittings.

4-6. Internal and External Transport by US Army Aircraft

The M.A.N. trucks exceed the size and weight limitations for internal or external transport by US Army fixed-wing aircraft or helicopters.

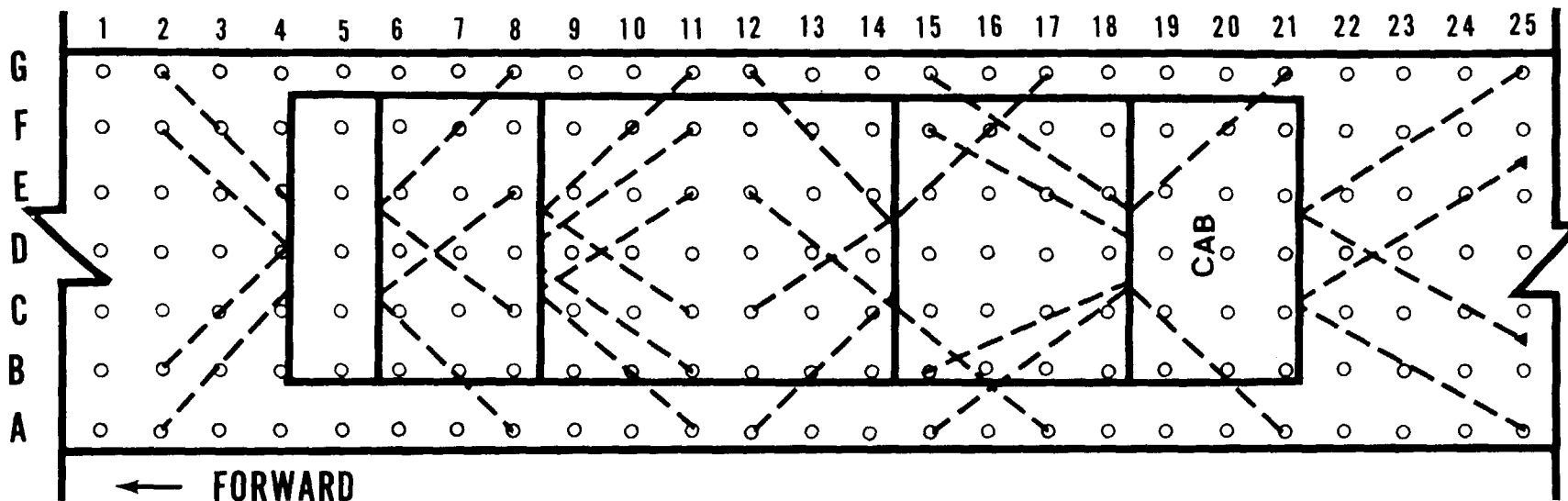

LEGEND: C-130 AIRCRAFT

- 10,000-POUND-CAPACITY TIEDOWN FITTING
- ▲ 25,000-POUND-CAPACITY TIEDOWN FITTING

NOTE: FLOOR TIEDOWN FITTINGS ARE LOCATED IN ROWS A THROUGH G AND COLUMNS 1 THROUGH 25. THE RAMP HAS 5 ADDITIONAL COLUMNS. THIS IS A TYPICAL TIEDOWN PROCEDURE AND ONLY COLUMNS 1 THROUGH 25 ARE SHOWN. ITEM BEING SHIPPED CAN BE TIED DOWN AT ANY LOCATION APPROVED BY THE LOADMASTER.

Figure 4-1. Typical tiedown diagram of the M. A. N. Truck in USAF C-130 aircraft

Table 4-1. Tiedown Data for the M. A. N. Truck in USAF C-130 Aircraft (Fig 4-1)

Tiedown fitting		Tiedown device		Attach to item
Designation	Capacity in 1,000 lb	Type	Capacity in 1,000 lb	
A2	10	MB-1	10	Right rear tiedown fitting.
B2	10	MB-1	10	Pintle.
F2	10	MB-1	10	Pintle.
G2	10	MB-1	10	Left rear tiedown fitting.
A8	10	MB-1	10	Around right side No.4 axle.
C8	10	MB-1	10	Left tiedown fitting No. 4 axle.
E8	10	MB-1	10	Around left side No. 4 axle.
G8	10	MB-1	10	Right tiedown fitting No.4 axle.
A11	10	MB-1	10	Right tiedown fitting No.3 axle.
B11	10	MB-1	10	Around right side No.3 axle.
C11	10	MB-1	10	Left tiedown fitting No.3 axle.
E11	10	MB-1	10	Right tiedown fitting No.3 axle.
F11	10	MB-1	10	Around left side No. 3 axle.
G11	10	MB-1	10	Left tiedown fitting No.3 axle.
A12	10	MB-1	10	Right tiedown fitting No. 2 axle.
C12	10	MB-1	10	Left tiedown fitting No. 2 axle.
E12	10	MB-1	10	Right tiedown fitting No. 2 axle.
G12	10	MB-1	10	Left tiedown fitting No. 2 axle.
A15	10	MB-1	10	Right tiedown fitting No.1 axle.
B15	10	MB-1	10	Around right side No.1 axle.
F15	10	MB-1	10	Around left side No.1 axle.
G15	10	MB-1	10	Left tiedown fitting No.1 axle.
A17	10	MB-1	10	Right tiedown fitting No. 2 axle.
G17	10	MB-1	10	Left tiedown fitting No.2 axle.
A21	10	MB-1	10	Right tiedown fitting No.1 axle.
G21	10	MB-1	10	Left tiedown fitting No.1 axle.
A25	10	MB-1	10	Right forward tiedown fitting.
G25	10	MB-1	10	Left forward tiedown fitting.
C25	25	MB-2	25	Right forward tiedown fitting.
E25	25	MB-2	25	Left forward tiedown fitting.

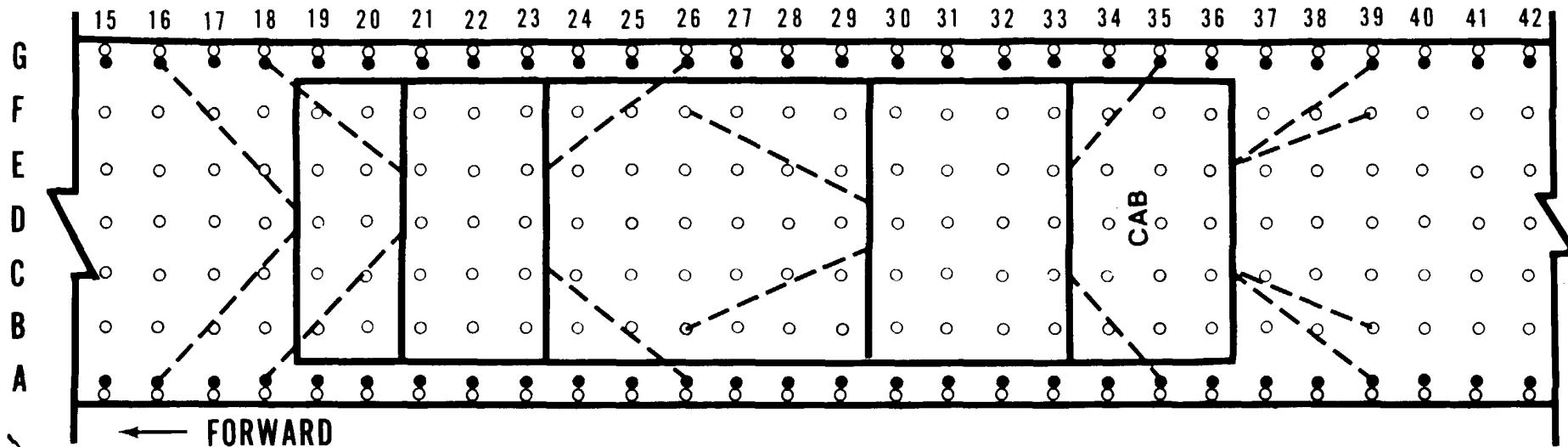

LEGEND: C-141 AIRCRAFT

- 10,000-POUND-CAPACITY TIEDOWN FITTING
- 25,000-POUND-CAPACITY TIEDOWN FITTING

NOTE: FLOOR TIEDOWN FITTINGS ARE LOCATED IN ROWS A THROUGH G AND COLUMNS 1 THROUGH 56. THE RAMP HAS 6 ADDITIONAL COLUMNS. THIS IS A TYPICAL TIEDOWN PROCEDURE AND ONLY COLUMNS 15 THROUGH 42 ARE SHOWN. ITEM BEING SHIPPED CAN BE TIED DOWN AT ANY LOCATION APPROVED BY THE LOADMASTER.

Figure 4-2. Typical tiedown diagram of the M.A.N. truck in USAF C-141 aircraft.

Table 4-2. Tiedown Data for the M. A. N. Truck in USAF C-141 Aircraft (Fig 4-2)

Tiedown fitting		Tiedown device		Attach to item
Designation	Capacity in 1,000 lb	Type	Capacity in 1,000 lb	
A16	25	MB-2	25	Right rear tiedown fitting.
G16	25	MB-2	25	Left rear tiedown fitting.
A18	25	MB-2	25	Around right side No. 4 axle.
G18	25	MB-2	25	Around left side No. 4 axle.
A26	25	MB-2	25	Around right side No. 3 axle.
B26	10	MB-1	10	Around right side No. 2 axle.
F26	10	MB-1	10	Around left side No. 2 axle.
G26	25	MB-2	2a	Around left side No. 3 axle.
A35	25	MB-2	2a	Around right side No. 1 axle.
G35	25	3IB-2	2a	Around left side No. 1 axle.
A39	25	MB-2	2a	Right side tiedown fitting.
B39	10	3IB-1	10	Right side tiedown fitting
F39	10	MB-1	10	Left side tiedown fitting.
G39	25	MB-2	2a	Left side tiedown fitting.

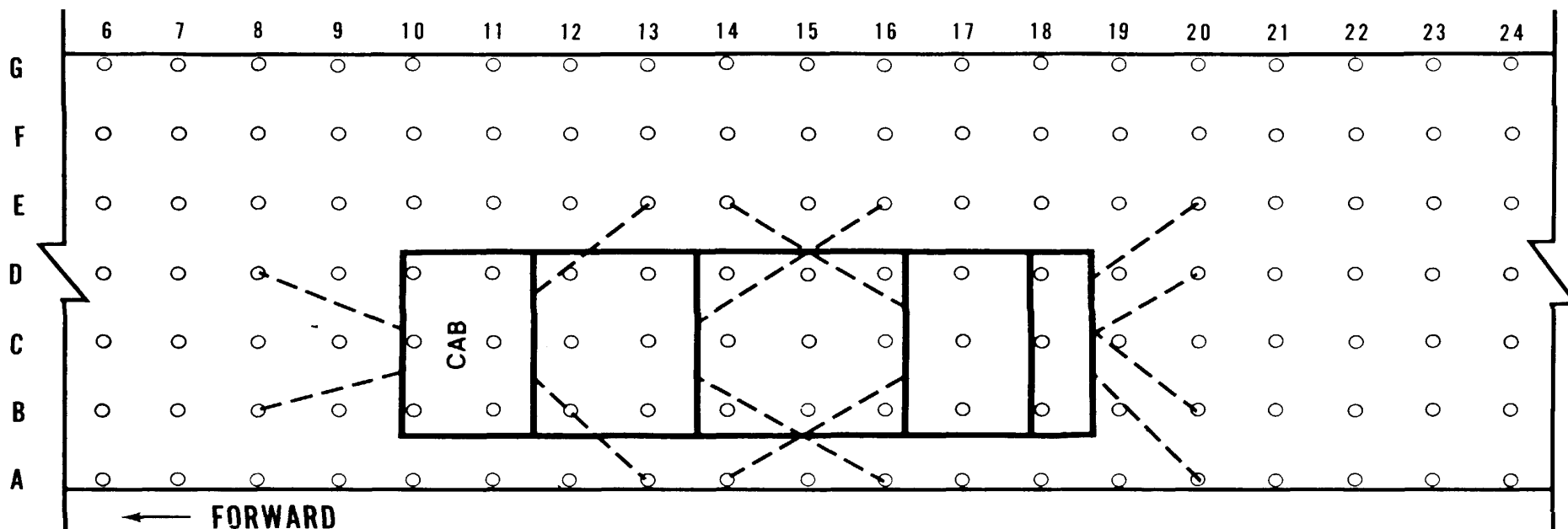

LEGEND: C-5 AIRCRAFT

○ ALL CARGO TIEDOWN FITTING RATINGS 25,000-LB EACH

NOTE: FLOOR TIEDOWN FITTINGS ARE LOCATED IN ROWS A THROUGH G AND COLUMNS 1 THROUGH 38. ADDITIONAL COLUMNS OF TIEDOWNS ARE LOCATED ON THE RAMPS: FOUR ON THE FORWARD RAMP AND FIVE ON THE AFT RAMP. THIS IS A TYPICAL TIEDOWN PROCEDURE AND ONLY COLUMNS 6 THROUGH 24 ARE SHOWN. ITEM BEING SHIPPED CAN BE TIED DOWN AT ANY LOCATION APPROVED BY THE LOADMASTER.

Figure 4-3. Typical tiedown diagram of the M. A. N. Truck in USAF C-5 aircraft

Table 4-3. Tiedown Data for the M. A. N. Truck in USAF C-5 Aircraft (Fig 4-3)

Tiedown fitting		Tiedown device		
Designation	Capacity in 1,000 lb	Type	(Capacity in 1,000 lb	Attach to item
B8	25	MB-2	25	Left front tiedown fitting.
D8	25	MB-2	25	Right front tiedown fitting.
A13	25	MB-2	25	Left tiedown fitting No. 1 axle.
E13	25	MB-2	25	Right tiedown fitting No. 1 axle.
A14	25	MB-2	25	Left tiedown fitting No. 3 axle.
E14	25	MIB-2	25	Right tiedown fitting No. :3 axle.
A16	25	MB-2	25	Left tiedown fitting No. 2 axle.
E16	25	MB-2	25	Right tie(down fitting No. 2 axle.
A20	25	MB-2	25	Left rear tie(down fitting.
B20	25	MB-2	25	Pintle.
D20	25	M1-2	25	Pintle.
E20	25	MB-2	25	Right rear tiedown fitting.

CHAPTER 5

HIGHWAY TRANSPORTABILITY GUIDANCE

Section I. GENERAL

5-1. Scope

This chapter provides highway transportability guidance for movement of the M.A.N. trucks. It covers technical and physical characteristics, as well as safety considerations. It also prescribes the materials and guidance required to prepare, load, tie down, and unload the trucks.

5-2. Safety

Besides the safety precautions in chapter 3, movement is subject to all safety laws, rules, and regulations that apply to commercial carriers. Theater regulations govern movements overseas.

Section II. SELF-PROPELLED MOVEMENT

5-3. US Highway

a. The length, height, axle loads, and gross vehicle weight of the M.A.N. trucks (without payload) are within the legal limits for highway transport in all States. The width of 98.43 inches (2.50 m) is within limits allowed by 28 States and on all interstate and designated Federal-aid primary highways. The width exceeds the limits for other Federal-aid and State highways in 22 States and will require permits for movement (AR 55-162).

b. Movement with payloads will encounter restrictions to highway transport according to the payloads towed. The truck tractor with a maximum payload semitrailer will exceed gross vehicle weight limits and therefore require permits. Dimensional limits exceeded depend on the dimensions of the semitrailer. The M1002 towing another M.A.N. vehicle will exceed length, gross weight, and tandem axleload limits in most States.

5-4. European Highways

Restrictions for movement of the M.A.N. trucks without payload will be minimal. Movement with payloads will encounter numerous restrictions throughout Europe and will require special permits and routing.

5-5. Other Country Highways

The M.A.N. vehicles without payloads may encounter restrictions in certain countries, but worldwide restrictions are minimal. With assigned payloads, numerous restrictions will be encountered, requiring permits and selective routing.

5-6. MTMC Assistance

MTMC can assist in obtaining highway movement approval for M.A.N. vehicles in the United States in certain instances. When movement can be certified as essential for national defense and no other transport mode can be used, the shipper will use AR 55-355, *Defense Traffic Management Regulation*, chapter 28, to request assistance.

Section III. TRANSPORT BY SEMITRAILER

5-7. Transport of the M.A.N. Trucks by Semitrailer

The M.A.N. vehicles are transportable by military or commercial semitrailers of adequate size and capacity. This section provides for movement of a disabled vehicle or movement for administrative purposes. The Army semitrailers suitable for transport of the M.A.N. truck tractor are the M871 and M872 towed by the M915 truck tractor. The recovery vehicle can be transported only on the M872 semitrailer. Movement by these semitrailers will be severely restricted because of the length, width, height, gross vehicle weight, and tandem axle loads. Restrictions in CONUS may be

resolved by obtaining permits. In overseas areas, permits and special routing will be required to transport the M.A.N. trucks on these semitrailers.

5-8. Preparation for Transport

WARNING

Do not allow personnel on the semitrailer bed during loading and unloading operations.

Preparation of the M.A.N. trucks for transport includes the following procedures:

- a. Secure all BII to preclude damage en route.
- b. Remove and stow the communication antenna.
- c. If a M.A.N. truck exceeds height restrictions, remove spare tire(s) and generator (M1001 only).
- d. If further height reduction is required, lower vehicle suspension and restrain axles according to

the procedures outlined in TM 9-2320-282-10, operator's manual.

- e. Place vehicle transmission in the neutral position and apply the parking brake.

5-9. Tiedown of M.A.N. Trucks

Figures 5-1 and 5-2 show the tiedown of the M.A.N. trucks. Tables 5-1 and 5-2 provide the bill of materials and application of materials.

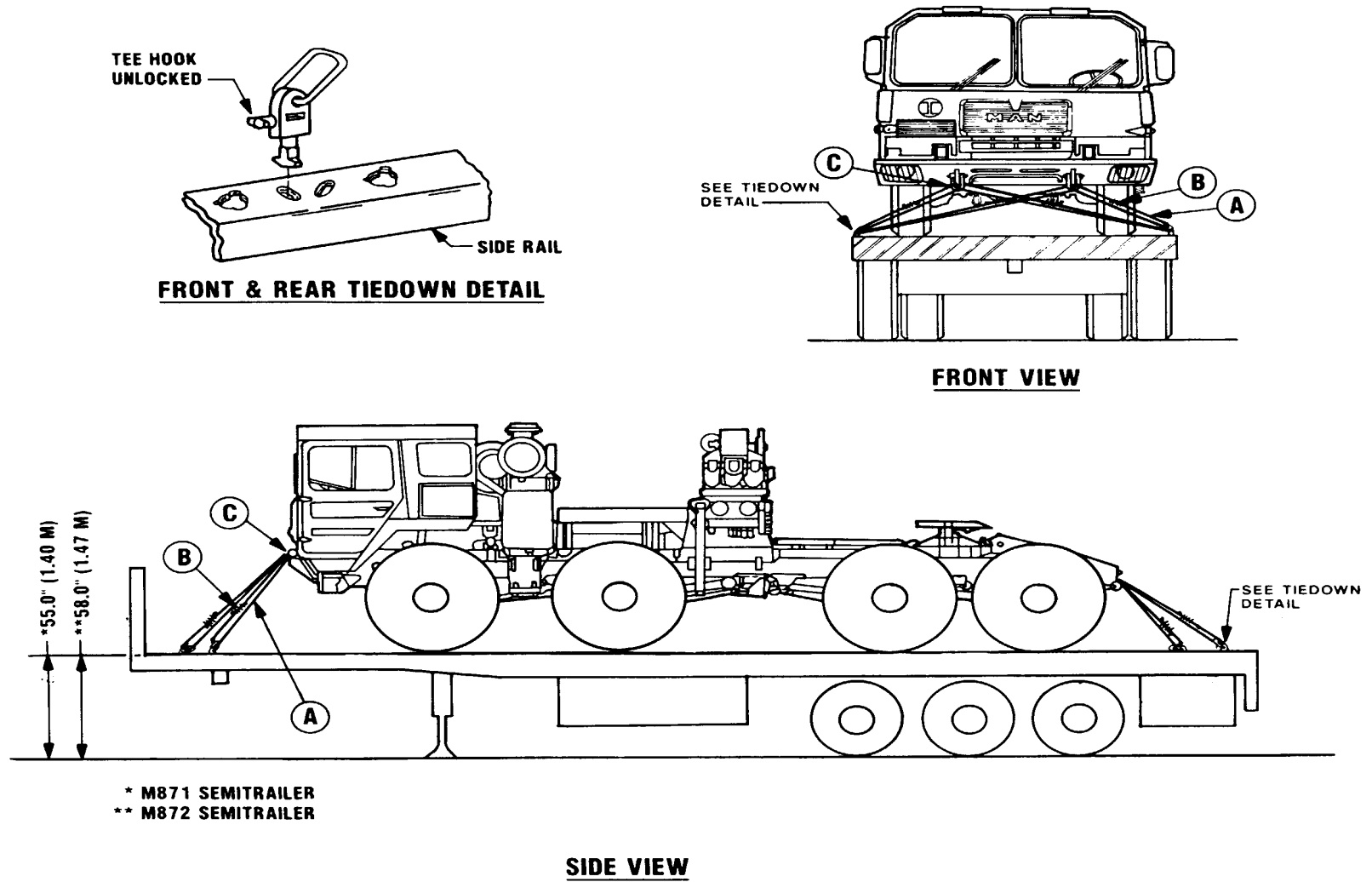
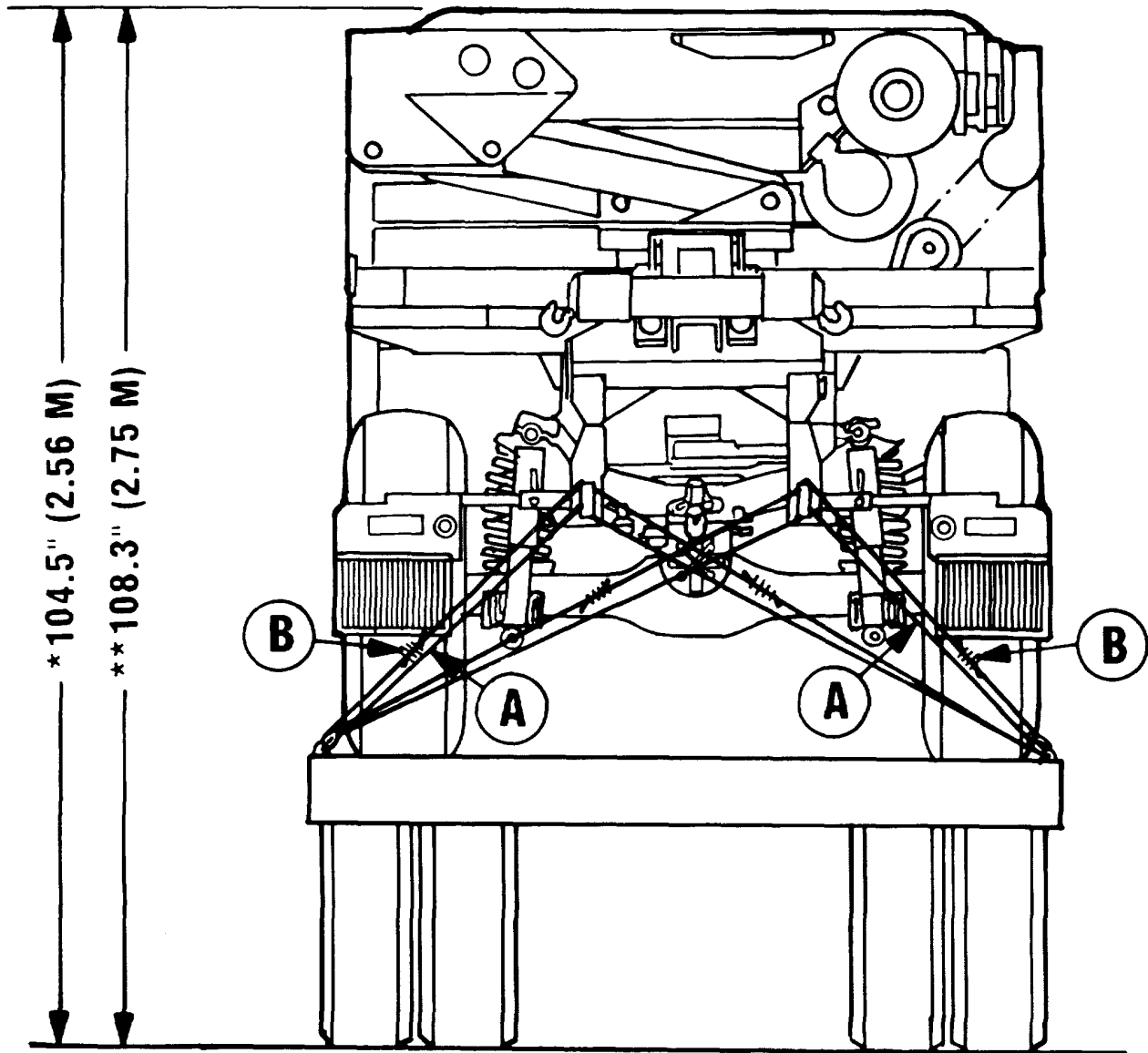

Figure 5-1. Tiedown of the M.A.N. truck on a semitrailer.



- * WHEN SUSPENSION IS LOWERED.
- ** HEIGHT WITH SPARE TIRE REMOVED.

Figure 5. Tiedown of the M. A. N. Truck on a semitrailer (rear view)

**Table 5-1. Bill of Materials for Tiedown of the M.A.N. Truck on M871 and M872 Semitrailers
(Figs 5-1 and 5-2)**

Item	Description	Approximate Quantity
Wire rope	6x19, IWRC, improved plow steel, preformed, regular-lay; table X, Fed Spec RR-W-410C: 5/8-inch	120 feet
Clamps	Wire-rope, U-bolt clamps, saddle, single-grip; steel, Crosby heavy-duty, or equal; Fed Spec FFG450, type 1: 5/8-inch 3/4-inch	32 8
Thimbles	Standard, open-type; table II, type II, Fed Spec FF-T-276: 5/8-inch	8
*Chains	Alloy steel chain, W-inch diameter; chains proof-tested at least 22,500 pounds; RR-C271, type I, grade C, class I welded steel alloy chains	8
*Load binders	Type I, plain, 18 1/2-inch, operating lever with two grabhooks designed for 1/4- to 1/2-inch chain; 16,000-8 pound safer-working rating; Fed Spec GGG-B325A, NSN 39910-171-9774	

*Chains and load binders may be used instead of wire rope.

**Table 5-2. Application of Materials for Tiedown of the M.A.N. Truck on M871 and M872 Semitrailers
(Figs 5-1 and 5-2)**

Item	No. Required	Application
A	8	Tiedowns. Each consists of one piece of 1/2-inch, 6x19, IWRC, wire rope, length as required (about 12 feet). Form a complete loop between truck tiedown provisions and appropriate semitrailer tiedown provision. The angle between the tiedowns and the semitrailer deck should be as close to 45° as possible. The wire rope ends should overlap at least 24 inches.
B	32	Clamps. Place four on each item A at overlap area. Space clamps 21/ inches apart, with at least 6 inches from ends of wire rope. Place one clamp on each item C. Tighten clamps so wire rope cannot slip.
C	8	Thimbles. Place one under wire rope where wire rope contacts semitrailer tiedown provision. Place one where wire rope goes through shackle.
NA	8	Chains. Attach one end of each chain to each front and rear tiedown shackle. Pull chains straight back and attach their ends to the semitrailer tiedown provision.
NA	8	Load binders. Tighten front and rear chains with load binders.

CHAPTER 6 MARINE AND TERMINAL TRANSPORTABILITY GUIDANCE

Section I. GENERAL

6-1. Scope

This chapter provides marine and terminal transportability guidance for movement of the M.A.N. trucks. It covers technical and physical characteristics, as well as safety considerations. It also prescribes the materials and guidance required to prepare, load, tie down, and unload the trucks.

6-2. Safety

Besides the safety precautions in chapter 3, the following procedures apply:

a. If ammunition and/or explosives are to be transported with the trucks, the activity offering the cargo for transport must notify the carrier, in compliance with paragraph 2-7, AR 55-228.

b. Ammunition, explosives, and vehicles will be handled and stowed according to the provisions in Water Carrier Tariff No. 31 and titles 46 and 49, Code of Federal Regulations.

c. Fire extinguishers must be available during all loading and unloading operations.

d. Vehicle fuel tanks must not be more than one fourth full.

6-3. Water Shipment

Marine transport of the M.A.N. trucks can be accomplished without significant restrictions because of vehicle dimensions or weight. Most ships have holds capable of stowing the M.A.N. trucks. Cargo ships require hold-by-hold analysis for hatch length, stowage height, and boom capacity. All Army logistics-over-the-shore (LOTS) craft except the LARC V and LARC XV can carry the M.A.N. trucks.

NOTE

The methods for lifting and securing M.A.N. trucks described in this chapter are recommended procedures. Other methods of handling and stowing may be used if they will ensure safe delivery without damage.

Section II. LOADING AND SECURING

6-4. General Rules for Stowing

a. *General.* When possible, stow the M.A.N. trucks below deck for protection. In general, good stowage of vehicles means placing vehicles fore and aft as close together as practicable, with minimum spacing between outer vehicles and sweatboards. Protect breakable parts and place spare parts within or near the vehicles. Stow vehicles in neutral, with brakes set and battery terminals disconnected. Secure vehicles with adequate lashing or blocking, lashing with wire rope or chain or blocking wheels on all four sides. Brace individual vehicle blocks to bulkheads, stanchions, and other vehicle blocks to prevent the vehicle from moving in any direction.

NOTE

Department of Transportation Exemption (DOT-E-7280) authorizes DOD to ship vehicles with fuel tanks three-quarters full on vessels adequately ventilated by power blowers, such as the roll-on/roll-off (RORO) vessels.

CAUTION

Failure to use lifting bars and appropriate spreader bars will result in damage to the vehicle.

b. *Lifting.* The front lifting provisions, because of their location, are not usable for standard sling lifting. RORO loading is the preferred loading method. If lifting is required, place lifting beams between the tandem axles (fig 6-1) or use lifting platform.

c. *Loading.* Vehicles are always loaded onto vessels in their minimum configuration; that is, reduced height, width, and length, with or without cargo. The vehicles can be lifted by crane of adequate capacity or driven onto landing craft, beach discharge and amphibious lighters, and tank landing ships. The vehicles can also be lifted by shoreside or floating cranes of adequate capacity onto seagoing vessels. Shoreside crane, floating cranes, and heavy-lift ship's gear of adequate capacity may be used to load vehicles onto vessels. The vehicles can be driven or towed onto roll-on/roll-off vessels. Some restrictions on the loading of M.A.N. trucks are anticipated because of the height of the vehicles. However, removing the generator from the M1001 and the spare tires from all vehicles will reduce the height to 108.3 inches.

d. *Tiedown.* Figure 6-2 shows typical blocking details for the M.A.N. trucks. Tables 6-1 and 6-2 list materials and their application.

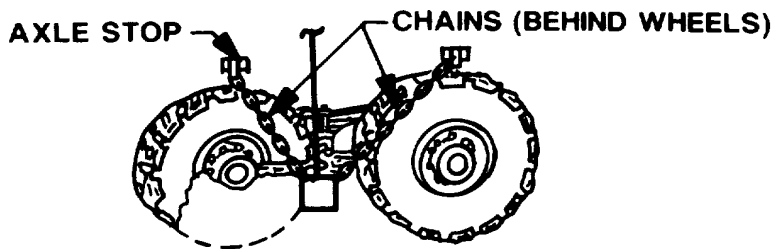
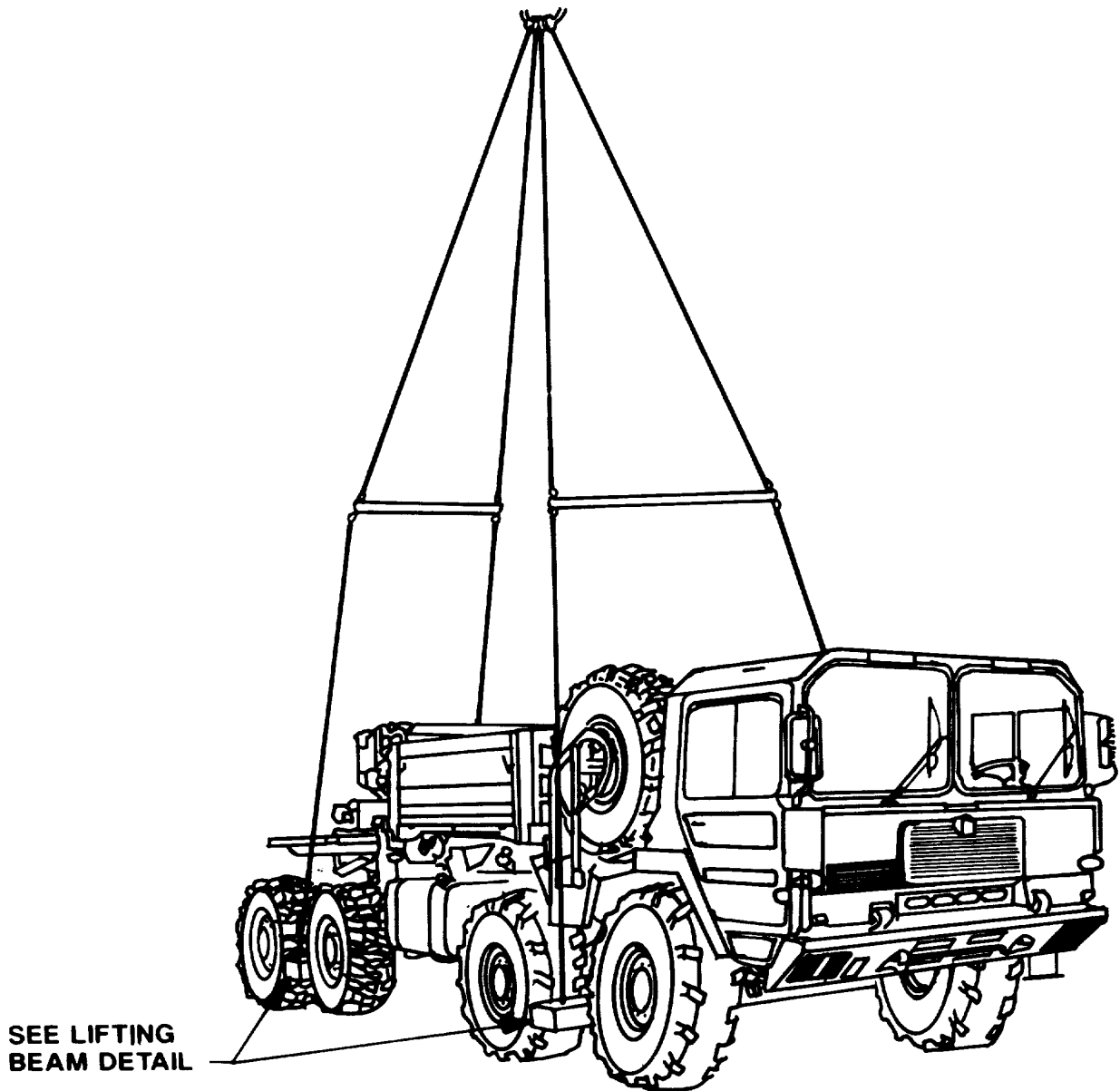

TYPICAL LIFTING BEAM DETAIL

Figure 6-1. Lifting diagram for the M.A.N. truck.

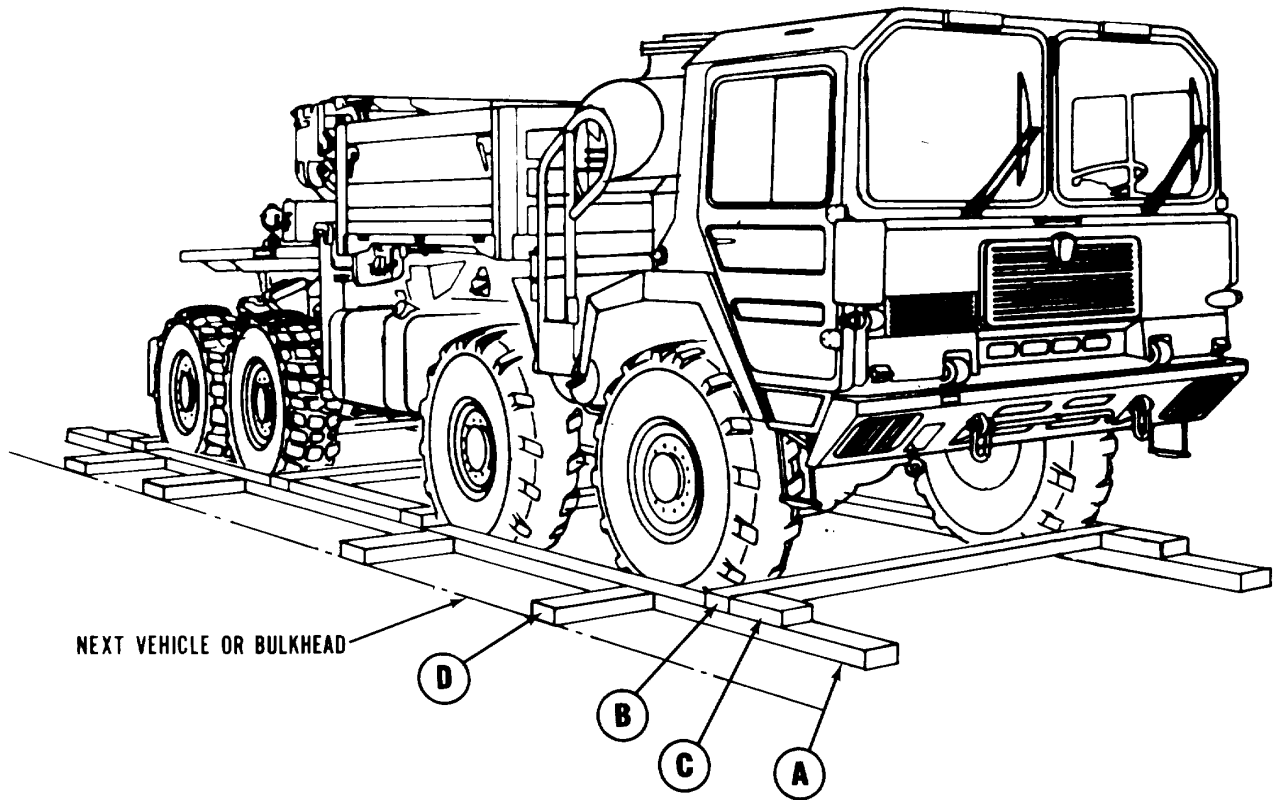

Figure 6-2. Blocking of the M.A.N. truck in a general cargo vessel.

Table 6-1. Bill of Materials for Blocking of the M.A.N. Truck in General-Cargo Vessel (Fig 6-2)

Item	Description	Approximate Quantity
Lumber	Douglas-fir, or comparable; straight-grain, free from material defects; Fed Spec MM-L-751H: 4- x 6-inch 6- x 8-inch	8 linear feet 96 linear feet
Nails	Common, steel; flathead; bright or cement-coated; Fed Spec FF-N-105B: 40d	64

Table 6-2. Application of Materials for Blocking of the M.A.N. Truck in a General-Cargo Vessel (Fig 6-2)

Item	No. Required	Application
A	4	Side blocks. Each consists of one piece of 6- x 8- x 144-inch lumber. Place one piece centered against outside of each pair of wheels.
B	4	End blocks. Each consists of one piece of 6- x 8- x 144-inch lumber. Place on top of item B and against wheels, as shown in figure 6-2. Toenail to item B with four 40d nails at each end of each item C.
C	8	Backup cleats. Each consists of one piece of 4- x 6- x 12-inch lumber. Place on top of item B against the joint of each item C. Nail to item B with four 40d nails each.
D	as required	Bracing. Each consists of 6- x 8-inch x length-cut-to-suit lumber. Brace as required against adjacent vehicle, cargo, or side of vessel bulkhead, as appropriate. Materials for this requirement are not included in table 6-1.

e. *Special Designs.* Seatrain trailer vessels, roll-on/ roll-off (RORO) vessels, landing ships, and attack-cargo vessels have patented lashing gear and prepositioned fittings in the deck. Proper application of the lashing gear removes the need for blocking and bracing.

6-5. General-Cargo Ships, Container Ships, and Roll-on/Roll-off (RORO) Ships

Below-deck stowage on general-cargo ships will have to be determined on a case-by-case basis of the height

of the M. A. N. trucks. In few instances, the length of the trucks may prevent them from being loaded through certain hatches. When the weight of a vehicle exceeds the boom capacity of some hatches, a shoreside crane will be required for loading. Normally, container ships would not be used for transport of the trucks. However, during a mobilization, the trucks could be loaded as deck cargo if hatch covers of sufficient strength are in place. Boom lift capacity and clearances and the availability of lifting beams or a lifting platform should be determined in advance planning actions. RORO ships are ideal for transport of the M. A. N. trucks.

6-6. Barges and Lighters

M.A.N. trucks can be transported in SEABEE barges and LASH lighters, with hatch covers in place. When transported on the lighters/barges, the M. A. .N trucks must be secured by blocking and bracing. Block wheels on all four sides, and

brace the individual wheel blocks to bulkheads, stanchions, or other vehicle blocks to prevent the vehicle from moving in any direction. Barge stability is noticeably affected by the placement of heavy-lift items; therefore, M.A.N. trucks should be loaded in a manner to counterbalance variations in the locations of centers of gravity from true center.

6-7. Landing Ships, Landing Craft, and Amphibious Vehicles

When the M.A.N. trucks are moved for extended distances or through rough waters, blocking and tiedowns must be used. In most cases, the vessels have turnbuckles with a sheep's-foot on one end that fits into a deck cloverleaf. Where not provided, a suitable substitute may be used. When the M.A.N. trucks are moved to or from vessels secured to piers or sheltered anchorages, only tiedowns will be required.

CHAPTER 7

RAIL TRANSPORTABILITY GUIDANCE

Section I. GENERAL

7-1. Scope

This chapter provides rail transportability guidance for movement of the M.A.N. trucks. It covers technical and physical characteristics, as well as safety considerations. It also prescribes the materials required to prepare, load, tie down, and unload the trucks.

7-2. Maximum Utilization of Railcars

Additional cargo, as approved by the activity offering the items for transport, may be loaded with the vehicles.

7-3. Safety

Besides the safety precautions in chapter 3, the following procedures apply:

- a. Ammunition, explosives, and vehicles will be handled and transported according to the provisions of titles 46 and 49, Code of Federal Regulations.
- b. The M.A.N. trucks should not exceed 3 mph on loading ramps.

Section II. TRANSPORT ON CONUS RAILWAYS

7-4. General

The transportability guidance in this section applies when the vehicle is transported on CONUS railways. When loaded on a 50-inch (1.27-m) deck-height flatcar, the M.A.N. trucks are within the height and width limitations of the Association of American Railroads (AAR) "Outline Diagram for Single Loads Without End Overhang on Open-Top Cars" and can be readily moved. No reduction or special preparation of the M.A.N. trucks will be required.

7-5. Preparation for Loading

As a minimum:

- a. Remove and stow antennas.
- b. Stow and secure all BII to prevent damage or theft.

7-6. Loading on General Purpose Flatcars

The M.A.N. trucks may be driven onto the flatcar or lifted into position by a crane of adequate capacity. Figure 7-1 is a tiedown diagram compatible with standard loading practices that will offer adequate restraint. Figure 7-2 shows blocking and tiedown details. Tables 7-1 and 7-2 provide the bill and application of materials for blocking and tiedown, respectively.

CAUTION

When a crane is used for loading a M.A.N. truck, lifting beams and spreader bars must be used (fig 6-1) to prevent damage to the vehicle.

Section III. TRANSPORT ON FOREIGN RAILWAYS

7-7. General

The transportability guidance in this section applies when the M.A.N. trucks are transported on foreign railways. When loaded on a suitable flatcar, the M.A.N. truck is transportable, with some restrictions, within European countries complying with the Gabarit International de Chargement (GIC) gauge railways. Transport in most of the countries in the Middle East and South America and in Australia, India, and Pakistan should also be possible. In the Middle East and South America, the clearances vary by country, and each country will require a separate check. In Australia, India, and Pakistan, wide or broad-gauge railways provide

greater clearances and fewer restrictions. Because of the various designation systems and clearances used by different countries, evaluation of transport capability must be made on an individual basis.

7-8. Transport on Foreign-Service Flatcars

The M.A.N. trucks are transportable on many foreign flatcars. To comply with the dimensional requirement of the GIC clearance diagrams, the M.A.N. trucks must be reduced to a height of 104.5 inches (2.66 m) by tiedown of the suspension system, removal of spare tires, and removal of the generator from the M1001 truck. Cranes on the M1001 and

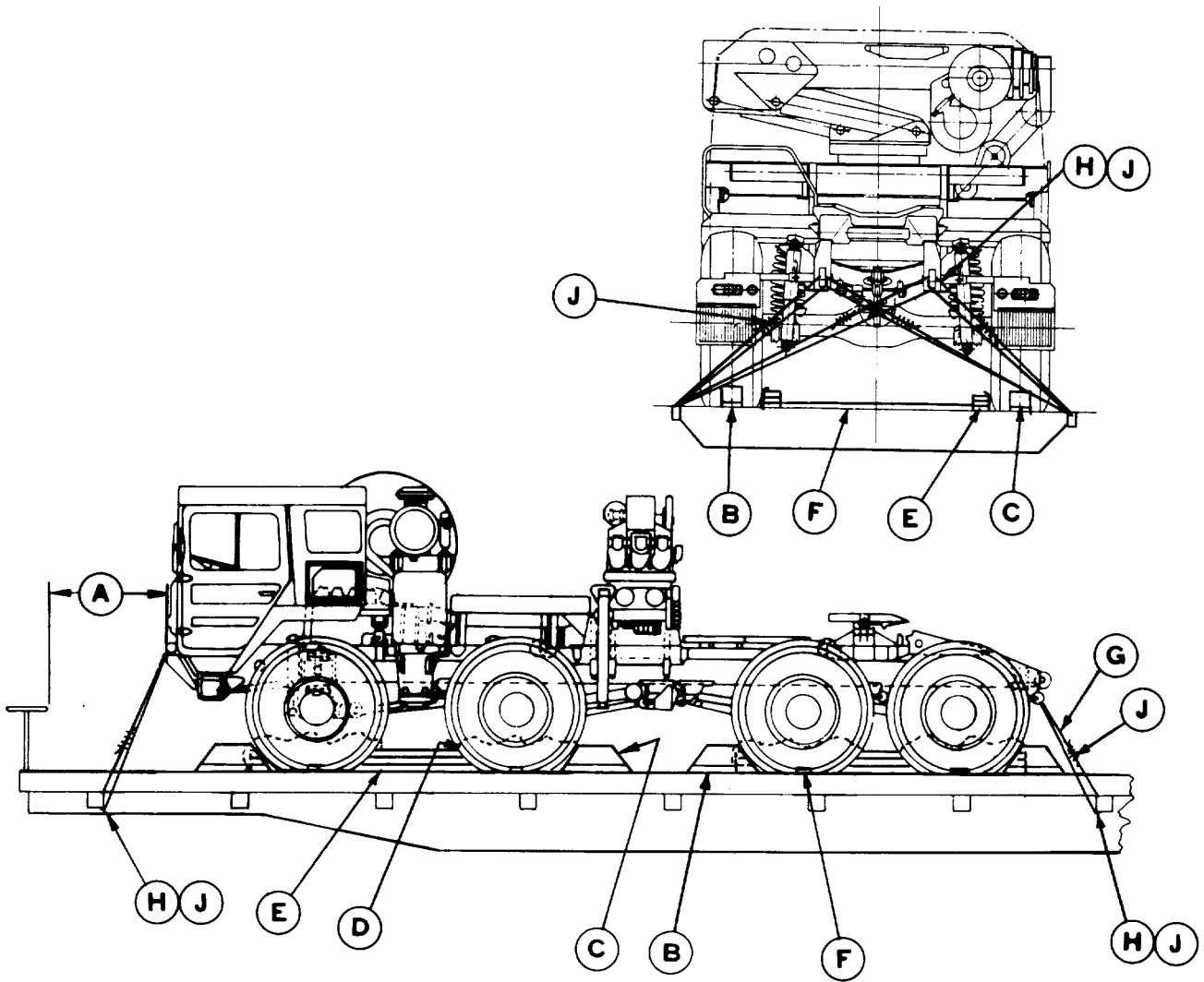

Figure 7-1. Blocking and tiedown of the M.A.N. truck on general-purpose flatcar.

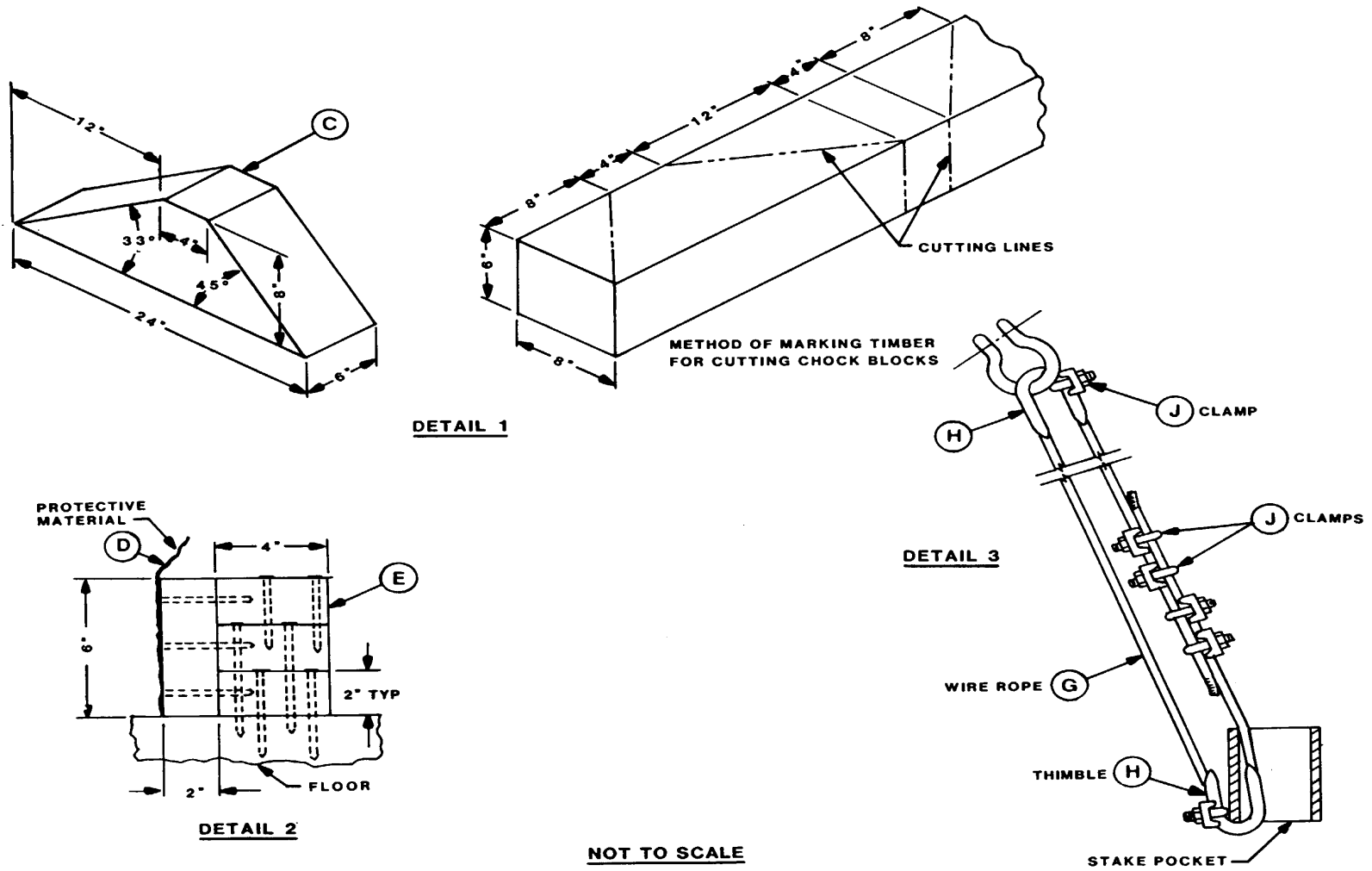

Figure 7-2. Blocking and tiedown details.

M1002 trucks must be turned to the longitudinal axis and secured. The crane on the M1013 truck must be turned 30° from the longitudinal axis and secured. With these dimensional reductions, the M.A.N. trucks can be moved without restriction on standard flatcars throughout Europe. The materials

required for blocking and tiedown of the trucks on foreign service flatcars are essentially the same as those materials used for rail within CONUS. Detailed guidance is contained in the 4th Transportation Command Pamphlet 55-2, Tiedown Guide of Rail Movements.

Table 7-1. Bill of Materials for Blocking and Tiedown of the M.A.N. Truck on CONUS General-Purpose Flatcar (Fig 7-1)

Item	Description	Approximate Quantity
Lumber	Douglas-fir, or comparable; straight-grain, free from material defects; Fed Spec MM-L-751H:	
	2- x 4-inch	108 linear feet
	2- x 6-inch	77 linear feet
Nails	6- x 8-inch	16 linear feet
	Common, steel; flathead; bright or cement-coated; Fed Spec FF-N-105B:	
	12d	60
Thimbles	20d	224
	40d	56
	Standard, open-type; table II, type II, Fed Spec F F-T-276: 5/8s-inch	16
Clamps	Wire-ropes, U-bolt clamps, saddled, single-grip, steel, Crosby heavy-duty, or equal; Fed Spec FF-C-450D; 5/8-inch	48
	6x19, IWRC; improved plow steel; preformed, regular-lay; table X, Fed Spec RR-W-410D; 5/8-inch	120 feet
Cushioning material	Waterproof paper, burlap, or other suitable material	as required

Table 7-2. Application of Materials for Blocking and Tiedown of the M.A.N. Truck on CONUS General-Purpose Flatcar (Fig. 7-1)

Item	No. Required	Application
A		Brake-wheel clearance. Minimum clearance required is 6 inches above, in back of, and on both sides of and 4 inches underneath wheel; 12 inches from end of railcar to load, which extends from center of brake wheel to side of railcar; and 6 feet above railcar floor (fig 7-1).
B	8	Blocks. Each consists of one piece of 2- x 6- x 25-inch lumber. Place one block against wheels as shown in figure 7-1, and nail to railcar floor with five 20d nails.
C	8	Block (fig 7-2). Each consists of one piece of 6- x 8- x 24-inch lumber. Place one block on top of each item B with 45° side against tire. Nail heel of block to item B with three 40d nails. Toenail sides of block to railcar floor through item B with two 40d nails on each side (Pattern 16).
D	1 per each item E	Cushioning materials. Place bottom portion under item E and between tire and item E so as to extend 2 inches above item E (fig 7-2).
E	4	Side block. Each consists of one piece of 2- x 6- x 108-inch lumber and three pieces of 2- x 4- x 108-inch lumber (fig 7-2). Nail 2- x 6- x 108-inch piece to bottom edge of 2- x 4- x 108-inch piece with fifteen 12d nails. Place 2- x 4- x 108-inch piece against inside of tires and cushioning materials, and nail to railcar floor with twelve 20d nails. Nail the other two 2- x 4- x 108-inch pieces to one below in the same manner (Pattern 89).
F	4	Brace. Each consists of one piece of 2- x 6-inch x length-cut-to-suit (about 72 inches) lumber. Place one piece under each axle between items E. Nail to car floor with ten 20d nails.
G	8	Wire rope, 5/8-inch. Each piece is about 20 feet long, as required. Form a complete loop between tiedown shackle and appropriate stake pocket at a maximum angle of 45° (fig 7-2). Ends of wire rope should overlap about 24 inches.
H	16	Thimbles. Place one under wire rope at each place where rope passes over bottom edge of stake pocket and also through tiedown shackle. Secure each thimble to wire rope with one 5/8-inch clamp (fig 7-2).
J	48	Clamps. Place four on each item H at overlap area. Space clamps 3 1/2 inches apart with at least 6 inches from ends of wire rope (fig 7-2). Place one on each item H as indicated above.

APPENDIX

REFERENCES

1. Army Regulations (AR)

55-29	Military Convoy Operations in CONUS
55-80	Highways for National Defense
55-162	Permits for Oversize, Overweight, or Other Special Military Movements on Public Highways in the United States
55-228	Transportation by Water of Explosives and Hazardous Cargo
55-355	Defense Traffic Management Regulation
70-44	DOD Engineering for Transportability
70-47	Engineering for Transportability
385-40	Accident Reporting and Records
746-1	Packaging of Army Materiel for Shipment and Storage

2. Fields Manuals (FM)

55-9	Unit Air Movement Planning
55-15	Transportation Reference Data
55-17	Terminal Operations Coordinator's Handbook

3. Supply Bulletins (SB)

700-20	Army Adopted/Other Items Selected for Authorization/List of Reportable Items
--------	--

4. Technical Bulletins (TB)

55-46-1	Standard Characteristics (Dimensions, Weight, and Cube) for Transportability of Military Vehicles and Other Outsize/Overweight Equipment
---------	--

5. Technical Manuals (TM)

9-2320-282-10	Operator's Manual
38-236(AFP 71-8)	Preparation of Freight for Air Shipment
38-250(AFR 71-4)	Packaging and Materials Handling: Preparing of Hazardous Materials for Military Air Shipments
55-500	Marine Equipment Characteristics and Data
55-2200-001-12	Transportability Guidance for Application of Blocking, Bracing, and Tiedown Materials for Rail Transport

6. Technical Orders (TO)

1-1B-40	Handbook of Weight and Balance Data
1C-5A-9	Loading Instructions, USAF Series C-5A Airplane
1C-141B-9	Loading Instructions, USAF Series C-141B Airplane
1C-130-9	Loading Instructions, USAF Series C-130 Airplane

7. Other Publications and Source of Procurement

- a. Code of Federal Regulations, Title 46-Shipping, Part 146, and Title 49-Transportation, Parts 170-179.

Available from:

Superintendent of Documents
US Government Printing Office
Washington, DC 20402

- b. Association of American Railroads, Rules Governing the Loading of Commodities on Open-Top-Cars and Trailers

Section No. 1-General Rules

Section No. 6-Rules Governing the Loading of Department of Defense Materials on Open-Top Cars

Available from: Association of American Railroads

50 F Street N. W.
Washington, DC 20001

c. American Trucking Association, Inc., *Summary of Size and Weight Limits*. Available from:
American Trucking Association, Inc.
2200 Mill Road
Alexandria, VA 22314-4654

8. Department of Transportation

Special Permit No. 3498

USCG 108 Rules and Regulations for Military Explosives and Hazardous Munitions

9. 4th Transportation Command Pamphlet 55-2, *Tiedown Guide for Rail Movements*.

By Order of the Secretary of the Army:

CARL E. VUONO
General, United States Army
Chief of Staff

Official:

WILLIAM J. MEEHAN II
Brigadier General, United States Army
The Adjutant General

DISTRIBUTION:

To be distributed in accordance with DA Form 12-34-E, block 0134, requirements for TM 55-2320-282-14.

RECOMMENDED CHANGES TO EQUIPMENT TECHNICAL PUBLICATIONS

SOMETHING WRONG WITH PUBLICATION



*THEN...JOT DOWN THE
DOPE ABOUT IT ON THIS FORM.
CAREFULLY TEAR IT OUT, FOLD IT
AND DROP IT IN THE MAIL.*

FROM: (PRINT YOUR UNIT'S COMPLETE ADDRESS)

DATE SENT

PUBLICATION NUMBER

PUBLICATION DATE

PUBLICATION TITLE

BE EXACT PIN-POINT WHERE IT IS

PAGE
NO.

PARA-
GRAPH

FIGURE
NO.

TABLE
NO.

IN THIS SPACE, TELL WHAT IS WRONG
AND WHAT SHOULD BE DONE ABOUT IT.

TEAR ALONG PERFORATED LINE

PRINTED NAME, GRADE OR TITLE AND TELEPHONE NUMBER

SIGN HERE

DA FORM 1 JUL 79 **2028-2**

PREVIOUS EDITIONS
ARE OBSOLETE.

P.S.--IF YOUR OUTFIT WANTS TO KNOW ABOUT YOUR
RECOMMENDATION MAKE A CARBON COPY OF THIS
AND GIVE IT TO YOUR HEADQUARTERS.

PIN: 058445-000